



BGR-15 SERIES

Bottom Mounted Glass Door Refrigerator

MODEL

BGR-15

FEATURES

CONSTRUCTION

- Standard interior LED lights
- Top LED-backlit graphic panel
- Electronic control
- Audio high temp alarm
- Six shelves
- High-density, CFC-Free polyurethane insulation

FINISH

- Galvanized white or black powder coated painted exterior
- Painted steel interior

DOORS

- Large low-E double pane tempered thermal glass door
- Self-closing door
- Door size:..... 24¹/₁₆ x 51"
- Black door frame
- Replaceable door gasket

REFRIGERATION

- Self-contained, factory tested, bottom mounted refrigeration system
- Automatic self defrost cycle
- Temperature range 35°F to 38°F (2°C to 3°C)

WARRANTY

- Standard limited two year parts and labor
- Additional three year coverage on compressor part



BGR-15 SERIES

BOTTOM MOUNTED GLASS DOOR REFRIGERATOR

TECHNICAL SPECIFICATIONS

MODEL	DIMENSIONS (in.)			DIMENSIONS (mm)			VOLTS	AMPS	UNIT H.P.	CAP. CU. FT.	SHIP CU. FT.	SHIP WT. (LB/KG)
	L	D	H	L	D	H						
BGR-15	25	24	75.5	635	610	1918	115	5.7	1/5	10.5	33.5	255/116

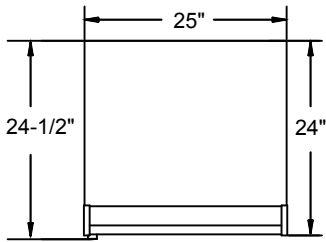

PLAN VIEW

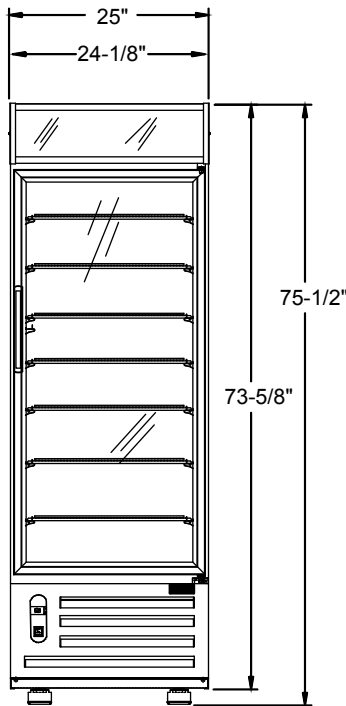

ELEVATION VIEW

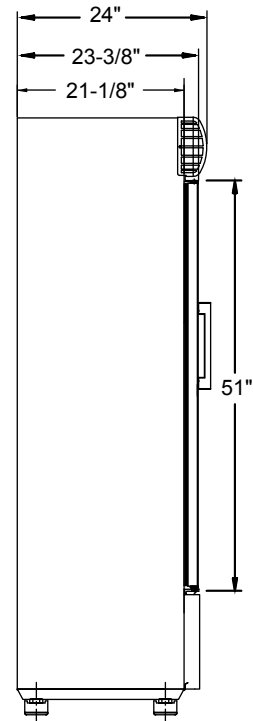

SIDE VIEW

LISTINGS



HOOKUP

Via plug in, 10 foot long, flexible three wire 14 ga. cord with molded plug.



BID SPECIFICATIONS

Item no. BGR-15. Provide ____ Bottom Mounted Glass Door Refrigerator, Master-Bilt model no. BGR-15.

Merchandise will feature a top LED-backlit graphic panel, LED interior lighting and an electronic controller system with visible temperature display & audio high temp alarm.

Self-closing door will feature large low-energy double pane tempered thermal glass.

The self-contained refrigeration system will be bottom mounted and will feature an automatic self-defrost cycle. Refrigerant will be R-134a. The temperature range will be 35° to 38°F (2° to 3°C).

Merchandise to have standard limited two year parts and labor with additional three year coverage on compressor part.

Merchandise to be ETL listed in the U.S. and Canada and ETL Sanitation listed.

NOTE: Cabinet designed for optimum performance in air-conditioned area at 75°F ambient and 55% relative humidity. All specifications subject to change without notice.



908 Highway 15 North • New Albany, MS 38652
 PHONE: 800-647-1284 or 662-534-9061 • FAX: 800-232-3966 or 662-534-6049 • www.master-bilt.com

