



**STANDARD
 INTERIOR LED
 LIGHTING**



BMG-SLP SERIES

Bottom Mounted
 Full-Height
 Slide Glass Door
 Refrigerator Merchandisers

MODELS

- BMG-48-SLP
- BMG-74-SLP

BMG-48-SLP

FEATURES

CONSTRUCTION

- Standard interior overhead LED lighting
- Electronic digital thermostat
- 24 gauge painted textured galvanized steel interior and exterior
- Standard finishes:
 White interior/white exterior or black exterior/black interior
- Stainless steel floor
- 1³/₄" thick state-of-the-art, foamed-in-place "zero ODP" polyurethane insulation provides high R-value
- Adjustable legs for leveling
- Four adjustable heavy-duty epoxy-coated cantilever shelves per door
- Merchandiser profile matches other BLG/BMG Plus refrigerator and freezer models

DOORS

- Full-height doors
- Auto-close, double pane, safety glass doors
- Contemporary style door frame

REFRIGERATION

- Self-contained bottom mount refrigeration system designed for optimum energy efficiency and low noise
- ENERGY STAR qualified, may be eligible for rebate programs
- Top mounted, low profile interior evaporator housing
- Energy-free condensate removal
- Refrigerant: R-134a
- Temperature range: 34° to 41°F (1° to 5°C)

WARRANTY

- **Standard limited three year parts and labor**
- **Additional two year coverage on compressor part**

OPTIONS

- Add suffix "R" for remote refrigeration
- Additional shelving
- Flat bottom shelf with legs
- Bottom baskets
- Casters



BMG-SLP SERIES

BOTTOM MOUNTED FULL-HEIGHT SLIDE GLASS DOOR REFRIGERATOR MERCHANDISERS

TECHNICAL SPECIFICATIONS

MODEL	DIMENSIONS (in.)			DIMENSIONS (mm)			VOLTS	AMPS	UNIT H.P.	NO. OF DOORS	NO. OF SHELVES	SHELF SIZE (in.)	CAP. CU. FT.	SHIP WT. (LB/KG)
	L	D*	H	L	D*	H								
BMG-48-SLP	52	30	79	1321	762	2007	115	6.9	1/3	2	8	23 ¹ / ₂ L x 21 ¹ / ₂ D	45.7	530/241
BMG-74-SLP	78	30	79	1981	762	2007	115	7.7	1/2	3	12	23 ¹ / ₂ L x 21 ¹ / ₂ D (outer doors), 25 ¹ / ₂ L x 21 ¹ / ₂ D (middle door)	70.2	715/325

*Does not include door handle.

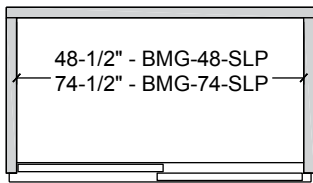

PLAN VIEW

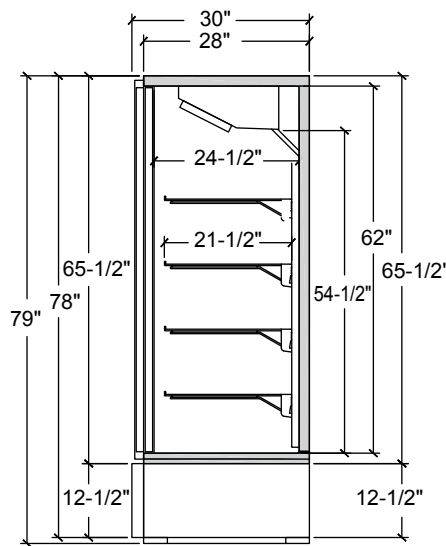

SIDE VIEW

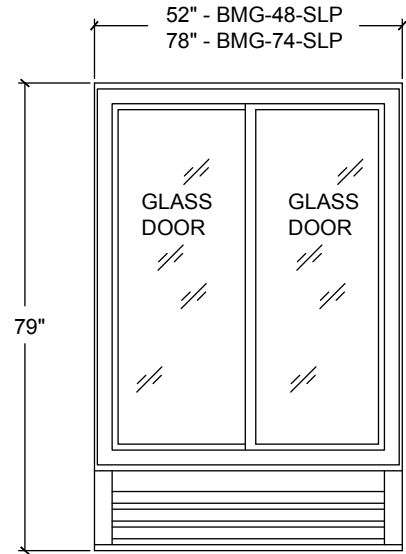

ELEVATION VIEW

LISTINGS



- Listed under NSF-7 for the storage and/or display of packaged food
- Meets 2012 Federal DOE Requirements
- Meets Canadian energy efficiency regulations

HOOKUP

All models via plug in, 10 foot long, flexible three wire 14/3 cord with molded plug.

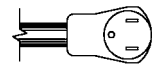

NEMA 5-15P

BID SPECIFICATIONS

Item no. BMG-____-SLP. Provide ____ Bottom Mounted Full-Height Slide Glass Door Refrigerator Merchandiser(s), Master-Bilt model no. BMG-____-SLP.

Merchandiser will be constructed of 24 ga. painted textured galvanized steel interior and exterior. Standard equipment includes interior overhead LED lighting and four epoxy-coated cantilever shelves per door.

Full-height, auto-close doors will be equipped with double pane safety glass.

Refrigeration system will be self-contained and designed for optimum energy efficiency and low noise. An energy-free condensate removal system will also be standard.

The refrigerant will be R-134a. Temperature range will be 5° to -15°F (-18° to -26°C).

Merchandiser to have standard limited

three year parts and labor warranty with additional two year coverage on compressor part.

Merchandiser to be UL and C-UL listed, UL EPH classified, and ENERGY STAR qualified. Merchandiser will also meet Canadian energy efficiency regulations.

NOTE: Cabinet designed for optimum performance in air-conditioned area at 75°F ambient and 55% relative humidity. All specifications subject to change without notice.



908 Highway 15 North • New Albany, MS 38652

PHONE: 800-647-1284 or 662-534-9061 • FAX: 800-232-3966 or 662-534-6049 • www.master-bilt.com

