



FIP-40



## FIP-40 SERIES

### Ice Cream And Novelty Display Merchandiser

Refrigeration system features low maintenance bare tube condenser coil.



#### MODEL

FIP-40

## FEATURES

### STANDARD TEXTURED FINISH



Standard white

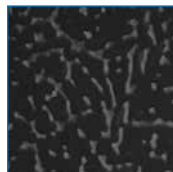

Black also available

#### CONSTRUCTION

- Standard electronic controller with these features:
  - Ability to monitor defrost functions from the front panel interface
  - Audible alarm
  - Eliminates room thermostat, defrost termination/fan delay control, defrost timer and digital thermometer or other temperature indicator
- 24 gauge steel interior and exterior

- Equipped with leveling legs to correct for unlevel flooring situations
- Stainless steel top serving deck
- Extra large, non-fogging front display window
- Four panes of tempered glass on front
- Backlit sign in stainless steel frame
- Two adjustable heavy-duty, white epoxy-coated, welded wire shelves
- Full length fluorescent lamp
- Automatic condensate evaporator
- Independent on/off light switch
- 2" foamed-in-place "zero ODP" urethane insulation

#### DOORS

- Replaceable magnetic door gasket
- Foamed-in-place reversible rear door
- Self-closing

#### REFRIGERATION

- Self-contained, hermetic condensing unit

- Automatic defrost
- Refrigerant: R-404A
- No minimum clearance required on cabinet sides but front, back and top must be left open for customer and operator access
- Temperature range: 0° to -20°F (-18° to -29°C)
- R-factor (insulation efficiency rating): 17.24

#### WARRANTY

- Standard limited two year parts and labor
- Additional three year coverage on compressor part

## OPTIONS

- Custom colors
- Extra shelf
- Casters



# FIP-40 SERIES

## ICE CREAM AND NOVELTY DISPLAY MERCHANDISER

### TECHNICAL SPECIFICATIONS

MODEL	DIMENSIONS (in.)			DIMENSIONS (mm)			VOLTS	AMPS	UNIT H.P.	NO. OF SHELVES	STANDARD SHELF SIZE (in inches)	DISPLAY AREA SQ. FT.	CAP. CU. FT.	SHIP CU. FT.	SHIP WT. (LB/KG)
	L	D	H	L	D	H									
FIP-40	40	31	50 <sup>3</sup> / <sub>16</sub>	1016	787	1270	115	13.6	3/4	2	19 x 35 <sup>1</sup> / <sub>4</sub>	7.5	11.8	46.4	427/194

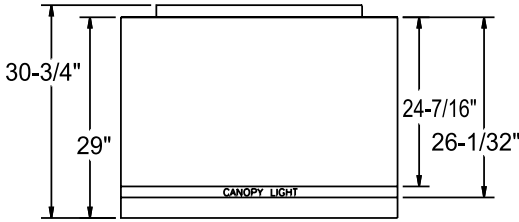

PLAN VIEW

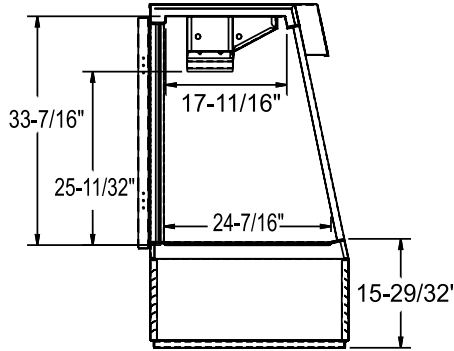

SIDE VIEW

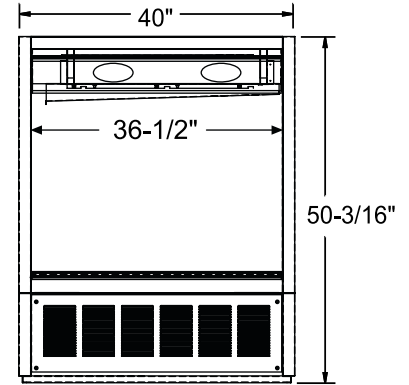

ELEVATION VIEW

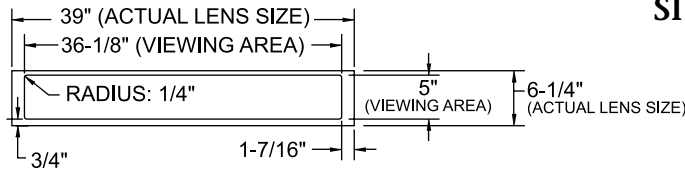

### NON-REMOVABLE LENS DIMENSIONS

### LISTINGS



### HOOKUP

Via plug in, 9 foot long, flexible 3 wire 14/3 cord with molded plug. Twenty amp service is required.

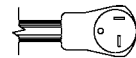

NEMA 5-20P

### BID SPECIFICATIONS

Item no. FIP-40

Provide \_\_\_\_\_ ( )

Low Temp Ice Cream and Novelty Display Merchandiser(s), Master-Bilt model no. FIP-40.

Merchandiser to be provided with an electronically controlled monitoring system.

Construction features include textured finish on interior and exterior, stainless steel top serving deck, extra large non-fogging front display window, four panes of tempered front glass, backlit sign in stainless steel frame, adjustable heavy-duty, white

epoxy-coated welded wire shelves, and a full length fluorescent lamp. Standard leveling legs provided to correct for unlevel flooring situations.

Merchandiser to also have automatic condensate evaporator and independent on/off light switch. Cabinet to be foamed-in-place with "zero ODP" urethane insulation and to have a sparkling white polyester enamel interior and exterior. The doors are to be self-closing and have magnetic door gaskets. Rear doors are to be

foamed-in-place.

The refrigeration system is to have a self-contained, hermetic condensing unit using R-404A refrigerant. Refrigeration system will also contain a low maintenance bare tube condenser coil. The temperature range is to be 0° to -20°F (-18° to -29°C).

Merchandiser to have standard limited two year parts and labor with additional three year coverage on compressor part. Merchandiser to be UL, C-UL and UL EPH listed.

**NOTE:** Cabinet designed for optimum performance in air-conditioned area at 75°F ambient and 55% relative humidity. All specifications subject to change without notice.



908 Highway 15 North • New Albany, MS 38652

PHONE: 800-647-1284 or 662-534-9061 • FAX: 800-232-3966 or 662-534-6049 • www.master-bilt.com

