



HOAM72

## HOAM SERIES

### Horizontal Open Air Merchandisers

#### MODELS

- HOAM36
- HOAM48
- HOAM60
- HOAM72



### FEATURES

#### CONSTRUCTION

- Contemporary styling provides an attractive product showcase
- Standard electronic controller with these features:
  - Ability to monitor defrost functions from the front panel interface
  - Audible and visual alarm
  - Eliminates room thermostat, defrost termination/fan delay control, defrost timer and digital thermometer or other temperature indicator
- 24 gauge painted textured galvanized steel interior and exterior
- Stainless steel floor pans
- Standard LED lighting in canopy
- Full length 10" wide metal top

- Adjustable shelf
- Automatic defrost
- 2" foamed-in-place "zero ODP" urethane insulation

#### REFRIGERATION

- Refrigerant: R-404A
- Front air intake and rear discharge
- Forced air ducted flow
- Self-contained, bottom mount refrigeration system
- Condensing unit slides out front of case for easy cleaning and servicing
- Temperature range: 34° to 41°F (1° to 5°C)
- R-factor (insulation efficiency rating): 17.24
- Standard energy efficient automatic condensate removal system

#### WARRANTY

- **Standard limited three year parts and labor**
- **Additional two year coverage on compressor part**

#### OPTIONS

- Add suffix "SS" for stainless steel interior and exterior
- Custom exterior colors
- Night curtain kit
- Casters
- Sandwich display deck
- Higher capacity condensate evaporator pan (depending on model)

### BID SPECIFICATIONS

Item no. HOAM \_\_\_\_\_  
 Provide \_\_\_\_\_ ( ) Horizontal Open Air Merchandiser(s), Master-Bilt model no. HOAM \_\_\_\_\_.

Merchandiser to be constructed of 24 gauge painted textured galvanized steel interior and exterior with stainless steel floor pans. Other standard features include an

electronically controlled monitoring system, full length 10" wide metal top, adjustable shelf, automatic defrost and 2" thick foamed-in-place "zero ODP" polyurethane insulation.

The refrigeration system is to be self-contained, have a front condenser air intake and rear discharge and use R-404A

refrigerant. The temperature range will be 34° to 41°F (1° to 5°C).

Merchandiser to have standard limited three year parts and labor warranty with additional two year coverage on compressor part.

Merchandiser to be UL & C-UL listed and UL-EPH classified.



# HOAM SERIES HORIZONTAL OPEN AIR MERCHANDISERS

## TECHNICAL SPECIFICATIONS

MODEL	DIMENSIONS (in.)			DIMENSIONS (mm)			VOLTS	AMPS*	UNIT H.P.	CAP. CU. FT.	SHIP WT. (LB/KG)
	L	D	H	L	D	H					
HOAM36	35 1/2	34	46	902	864	1168	115	8.0	1/2	4.6	350/159
HOAM48	47 1/2	34	46	1207	864	1168	115	8.0	1/2	6.3	450/205
HOAM60	59 1/2	34	46	1511	864	1168	115	11.5	3/4	7.9	550/250
HOAM72	71 1/2	34	46	1816	864	1168	115	11.5	3/4	9.6	650/295

\*Factory installed condensate evaporator pan requires a dedicated 15 amp, 120 volt circuit.

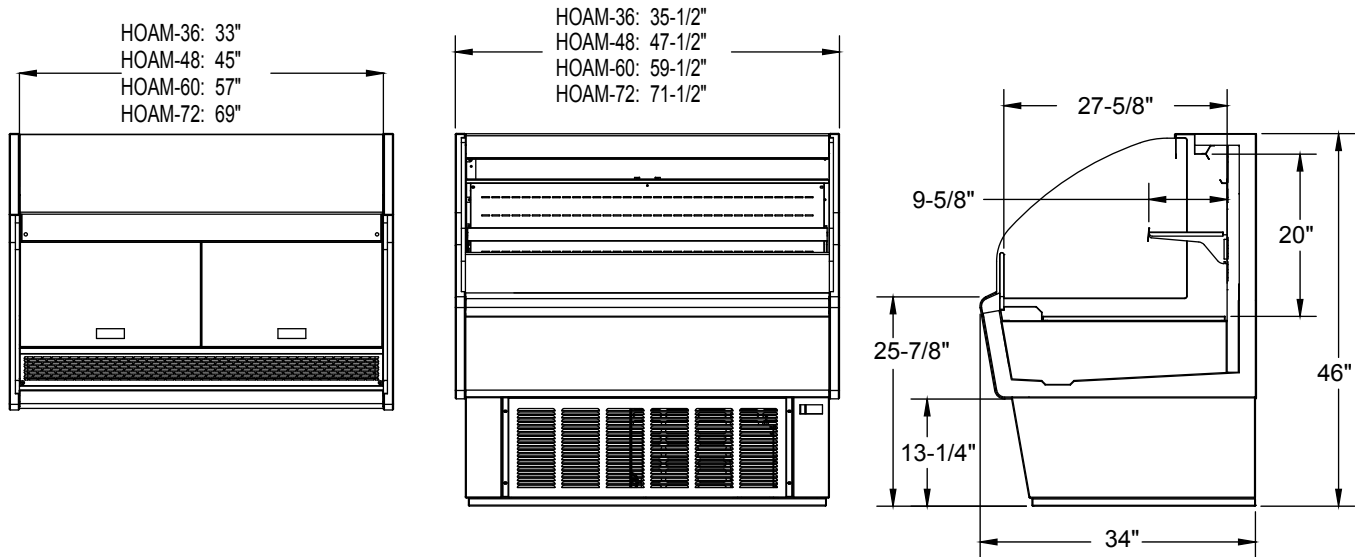

PLAN VIEW

ELEVATION VIEW

SIDE VIEW

### LISTINGS



### HOOKUP

All models via plug in, 9 ft. long, flexible 3 wire 14/3 cord with molded plug.

Condensate evaporator pan via plug in, 10 ft. long with molded plug.

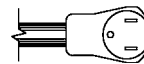

NEMA 5-15P (HOAM36 & HOAM48)

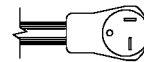

NEMA 5-20P (HOAM60 & HOAM72)  
- APPLIES TO U.S. MODELS ONLY, CANADIAN MODELS WILL NEED TO BE HARDWIRED.

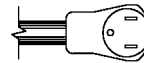

NEMA 5-15P (Condensate evaporator pan)

### RECOMMENDED OPERATING CONDITIONS

- Merchandisers designed to hold product in the 34° to 41°F (1° to 5°C) range
- Designed to operate in air-conditioned stores where the maximum temperature is 75°F and the maximum relative humidity is 55%
- Should not be installed in direct sunlight
- Should not be installed near HVAC vents, fans or doorways that will disrupt airflow and compromise the function of the air screen inside the case
- Bottom shelf should not be loaded such that the front air intake is obstructed
- Factory installed controls should not be altered, removed or replaced without consent of the factory
- Product must not be displayed in the cold air curtain

NOTE: All specifications subject to change without notice.



908 Highway 15 North • New Albany, MS 38652  
PHONE: 800-647-1284 or 662-534-9061 • FAX: 800-232-3966 or 662-534-6049 • www.master-bilt.com

