



## M B MASTER-BILT<sup>®</sup>

### MASTER-CHILL<sup>™</sup>

## MBCF SERIES

### Low Profile Blast Chiller/ Freezer

#### MODEL

MBCF35/22-5A



#### EXCLUSIVE F.I.C. TECHNOLOGY

The Food Identification Controller (F.I.C.) is the newest patented technology in blast chillers. The F.I.C. automatically adjusts blast chilling cycles with its single multi-sensor probe. The F.I.C. monitors temperatures in the core, beneath and on the surface, preventing surface freezing and degradation as well as preserving nutritional values of the food.

### FEATURES

#### CONSTRUCTION

- One-piece construction with rounded internal corners
- Stainless steel interior and exterior
- Satin Scotchbrite finish on door, side and control panels
- Stainless steel top, rounded on front side, with front control panel
- CFC-free polyurethane foamed-in-place insulation
- Wall thickness: 2.16"
- Hinged fan cover for easy cleaning access to the evaporator and fan
- Removable stainless steel wire rack, 10 positions, 1.6" vertical spacing intervals
- Plastic defrost drip tray on outer base
- Stainless steel feet height-adjustable from 5.9" to 7.9"

#### DOORS

- Self-closing door with full-width outer stainless steel handle and bottom foot pull
- Removable magnetic gasket
- Door frame heating element

#### CONTROL PANEL

- LCD control board with encoder, multi-lingual, multi-sector allowing selection between time-based abatement mode or core probe mode, which acts upon various parameters
- 20 pre-set blast-chilling cycles
- Variable speed drives on evaporator fans for accurate temperature control and energy efficiency
- Displays interior temperature, product temperature, ventilation speed
- Automatic setting of refrigerating phase at end of cycle
- HACCP alarms visible on display
- Alarms recorded on a list (nr. 30), including USB port

#### REFRIGERATION

- Refrigeration cell with rounded corners and condensation drain in base
- Cooling unit at evaporation temperature -10°F and condensation temperature 130°F rated at 901 watt
- Max room temperature: +89°F
- Refrigerant: R-404A

- Production per cycle: 35 lbs. of product from +194°F to +37°F in 90 minutes and 22 lbs. from +194°F to 0°F in 240 minutes
- Pre-set inner cell temperature during chilling cycle: +32, +23, -13°F
- Pre-set inner temperature during freezing cycle: -13°F
- Evaporation temperature control with thermostat valve
- Internal operation: ventilated cell, ventilation not directly on foods
- Copper/aluminum corrosion-proofed evaporator
- Electric defrost

#### WARRANTY

- Standard limited 1 year parts & labor
- Additional four year coverage on compressor part

#### OPTIONS

- Printer
- Additional wire shelves
- Additional support guides



# MASTER-CHILL™ MBCF SERIES

## LOW PROFILE BLAST CHILLER/FREEZER

### TECHNICAL SPECIFICATIONS

MODEL	DIMENSIONS (in.)			DIMENSIONS (mm)			VOLTS/ HZ/PH	AMPS	UNIT H.P.	SHIP CU. FT.	SHIP WT. LB/KG
	L	D	H*	L	D	H*					
MBCF35/22-5A	36 <sup>9</sup> / <sub>16</sub>	30 <sup>13</sup> / <sub>16</sub>	33 <sup>7</sup> / <sub>16</sub>	929	783	849	220/60/1	7.5	1	30.8	276/125

\*Height includes legs.

### PAN CAPACITIES

MODEL	1/1 GASTRONORM (530 x 325 x 40mm)	12" X 20" X 2.5"	12" X 20" X 1.5"
MBCF35/22-5A	5	5	10

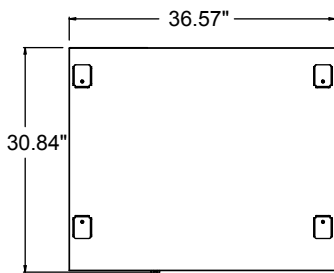

PLAN VIEW

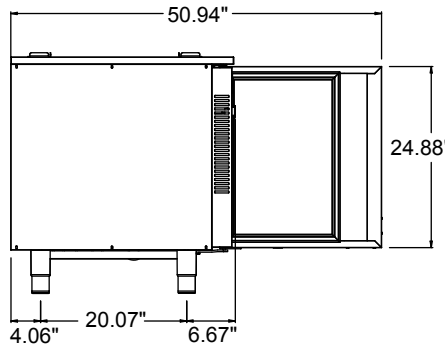

SIDE VIEW

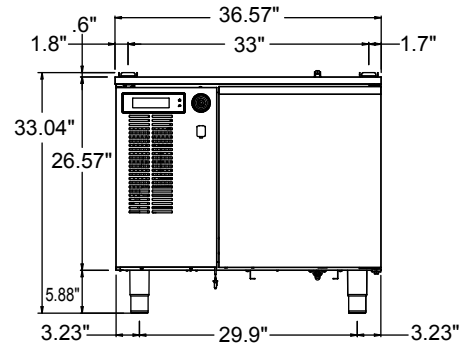

ELEVATION VIEW

### LISTINGS



### HOOKUP

Hardwired (cord and plug not included).

### BID SPECIFICATIONS

Item no. MBCF35/22-5A.

Provide \_\_\_\_\_ ( ) Low Profile Blast Chiller/Freezer(s), Master-Bilt model no. MBCF35/22-5A.

Blast chiller/freezer will be constructed of stainless steel interior and exterior with rounded internal corners.

Blast chiller/freezer will feature patented Food Identification Controller with single multi-sensor probe.

Other features will include:

- CFC-free polyurethane foamed-in-place insulation
- Hinged fan cover for easy cleaning access to the evaporator and fan

- Removable stainless steel wire rack, 10 positions, 1.2" vertical spacing intervals
  - Plastic defrost drip tray on outer base
  - Stainless steel feet height-adjustable from 5.9" to 7.9"
  - Self-closing door with full-width outer stainless steel handle and bottom foot pull
  - LCD control board with encoder, multi-lingual, multi-sector allowing selection between time-based abatement mode or core probe mode, which acts upon various parameters
- The refrigeration system is to be self-contained and use R-404A refrigerant.

Production per cycle will be 48 lbs. of product from +194°F reduced to +37.4°F in 90 minutes and 28 lbs. from +194°F to 0°F in 240 minutes.

System will also feature a copper/aluminum corrosion-proofed evaporator and electric defrost.

Blast chiller/freezer to have standard limited one year parts and labor with additional four year coverage on compressor part.

Blast chiller/freezer will be ETL listed in the U.S. and Canada and ETL Sanitation listed.

**NOTE:** Cabinet designed for optimum performance in air-conditioned area at 75°F ambient and 55% relative humidity. All specifications subject to change without notice.



908 Highway 15 North • New Albany, MS 38652  
PHONE: 800-647-1284 or 662-534-9061 • FAX: 800-232-3966 or 662-534-6049 • www.master-bilt.com

