



## MDT SERIES

### Multi-deck Open Front Merchandisers

#### MODELS

- MDT-06
- MDT-08

MDT-06  
(shown with  
ends installed)



## FEATURES

### NEW STANDARD TEXTURED FINISH

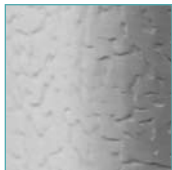

Standard  
white

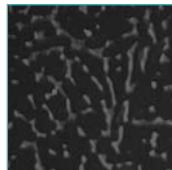

Black also  
available

#### CONSTRUCTION

- Can be used as either stand-alone units or combined in a modular endless design
- Ends must be ordered separately
- Mirrored interiors on end panels
- 24 gauge painted textured galvanized steel interior and exterior
- Horizontal electronic lighting
- Drum thermometer
- Fans mounted on hinge panels for easy access
- 2" foamed-in-place "zero ODP" urethane insulation
- 22" deep solid shelving with standard price tag molding
- Number of shelves:
 

MDT-06 .....	12
MDT-08 .....	16
- Cabinet cubic feet:
 

MDT-06 .....	48.9
MDT-08 .....	65.3

- Refrigeration lines and drain line connections designed to be easily accessed for installation purposes
- Minimum 6" clearance required between cabinet back and wall
- Temperature range: 34° to 41°F (1° to 5°C)
- R-factor (insulation efficiency rating): 17.24

#### WARRANTY

- Two year limited parts and 90 day labor

### STANDARD NIGHT CURTAINS AID IN ENERGY EFFICIENCY



#### REFRIGERATION

- Available with remote refrigeration system only
- Refrigerant: R-404A

## OPTIONS

- Custom colors
- Lower light assembly
- Stainless steel kickplate
- Extra shelves
- Left and right hand end kits



# MDT SERIES MULTI-DECK OPEN FRONT MERCHANDISERS

## TECHNICAL SPECIFICATIONS

OVERALL LENGTH*	OVERALL HEIGHT	OVERALL DEPTH	MODELS REQUIRED		CASE AMP DRAW			NORMAL AMBIENT CONDENSING UNIT UP TO 100°F**		HIGH AMBIENT CONDENSING UNIT 100°F TO 120°F**	
					120V LIGHTS	230V DEF. HTRS.	230V FANS	UNIT MODEL	BTUH @ +15°F SUCTION, 120°F CONDENSING	UNIT MODEL	BTUH @ +15°F SUCTION, 140°F CONDENSING
			MDT-06	MDT-08							
6'0"	80 <sup>1</sup> / <sub>8</sub> "	37 <sup>1</sup> / <sub>2</sub> "	1		1.0	4.4	0.6	MHHZ0171	8720	MHHZ0221	8000
8'0"	80 <sup>1</sup> / <sub>8</sub> "	37 <sup>1</sup> / <sub>2</sub> "		1	1.0	6.1	0.9	MHHZ0191	10,300	MHHZ0331	10,800
12'0"	80 <sup>1</sup> / <sub>8</sub> "	37 <sup>1</sup> / <sub>2</sub> "	2		2.0	8.8	1.2	MHHZ0331	17,200	MHHZ0431	15,300
14'0"	80 <sup>1</sup> / <sub>8</sub> "	37 <sup>1</sup> / <sub>2</sub> "	1	1	2.0	10.5	1.5	MHHZ0431	23,900	MHHZ0501	19,200
16'0"	80 <sup>1</sup> / <sub>8</sub> "	37 <sup>1</sup> / <sub>2</sub> "		2	2.0	12.2	1.8	MHHZ0431	23,900	MHHZ0501	19,200
18'0"	80 <sup>1</sup> / <sub>8</sub> "	37 <sup>1</sup> / <sub>2</sub> "	3		3.0	13.2	1.8	MHHZ0431	23,900	MSHZ0501	24,900
20'0"	80 <sup>1</sup> / <sub>8</sub> "	37 <sup>1</sup> / <sub>2</sub> "	2	1	3.0	14.9	2.1	MHHZ0501	28,000	MSHZ0501	24,900
22'0"	80 <sup>1</sup> / <sub>8</sub> "	37 <sup>1</sup> / <sub>2</sub> "	1	2	3.0	16.6	2.4	MHHZ0501	28,000	MSHZ0581C	30,300
24'0"	80 <sup>1</sup> / <sub>8</sub> "	37 <sup>1</sup> / <sub>2</sub> "		3	3.0	18.3	2.7	MSHZ0501	33,400	MSHZ0581C	30,300
26'0"	80 <sup>1</sup> / <sub>8</sub> "	37 <sup>1</sup> / <sub>2</sub> "	3	1	4.0	19.3	2.7	MSHZ0501	33,400	BSHZ0750C	37,400
28'0"	80 <sup>1</sup> / <sub>8</sub> "	37 <sup>1</sup> / <sub>2</sub> "	2	2	4.0	21	3	MSHZ0581C	39,600	BSHZ0750C	37,400
30'0"	80 <sup>1</sup> / <sub>8</sub> "	37 <sup>1</sup> / <sub>2</sub> "	1	3	4.0	22.7	3.3	MSHZ0581C	39,600	BSHZ0750C	37,400

\*Total overall length without ends. Add 2" for each end. †Add suffix "B" for single phase unit or "C" for three phase.

**NOTE: BTUH LOAD AND UNIT SIZES ARE BASED ON A 75°F, 55% RELATIVE HUMIDITY (MAXIMUM) STORE.**

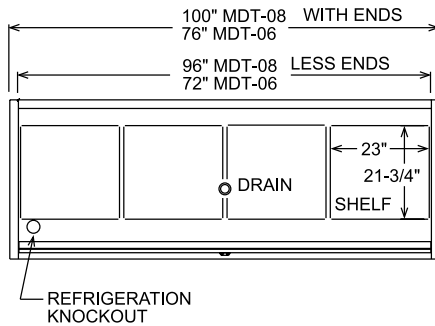

PLAN VIEW

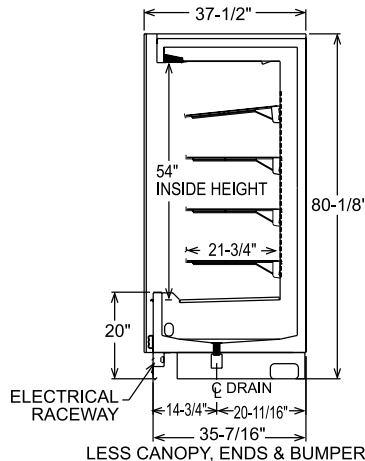

SIDE VIEW

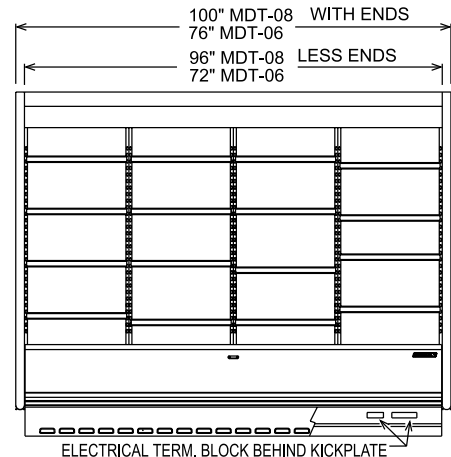

ELEVATION VIEW

## HOOKUP

Hardwire, remote refrigeration.

## BID SPECIFICATIONS

Item no. MDT-\_\_\_\_\_  
Provide \_\_\_\_\_ ( ) Multi-deck Open Front Merchandiser(s), Master-Bilt model no. MDT-\_\_\_\_\_.

Merchandiser to be constructed of 24 gauge painted textured galvanized steel interior and exterior with 2" foamed-in-place "zero ODP" urethane insulation. Merchandiser may

be used as either a stand-alone unit or combined in a modular endless design. Merchandiser supplied with mirrored interiors on end panels, horizontal electronic lighting, drum thermometer and 22" deep solid shelving with standard price tag molding. Evaporator fans will be mounted on hinge panels for easy access.

Merchandiser available with remote re-

frigeration system only. System uses R-404A refrigerant. Refrigeration lines and drain line connections designed to be easily accessed for installation purposes. The temperature range will be 34° to 41°F (1° to 5°C).

Merchandiser to be UL and C-UL listed and UL EPH classified. Merchandiser to have two year limited parts and 90 day labor warranty.

**NOTE: Cabinet designed for optimum performance in air-conditioned area at 75°F ambient and 55% relative humidity. All specifications subject to change without notice.**



908 Highway 15 North • New Albany, MS 38652  
PHONE: 800-647-1284 or 662-534-9061 • FAX: 800-232-3966 or 662-534-6049 • www.master-bilt.com

