

ITEM NO. _____
PROJECT _____
LOCATION _____
DATE _____ QTY. _____



MPWR SERIES Roll-Thru Refrigerators

MODELS

- MPWR332
- MPWR724



FEATURES

STANDARD ELECTRONIC CONTROL

- Increases efficiency, reliability and convenience
- Allows user to easily monitor and adjust defrost functions from the panel interface on the front of the merchandiser
- Decreases service time and calls
- Eliminates cabinet thermostat, defrost timer and digital thermometer or other temperature indicator

CONSTRUCTION

- Exterior front, sides and doors are stainless steel
- Exterior top, bottom and back are galvanized steel
- All exterior joints and seams fold in without lap joints
- Interior liner and door panel are stainless steel
- 2" foamed-in-place polyurethane insulated walls
- Interior LED light activated by switches for each door
- Interior stainless steel bumper/cart guides
- Maximum cart size:
24"L x 29³/₄"D x 65¹/₂"H

DOORS

- Available with lefthand or righthand door swing
- Heavy-duty pivot hinges
- Centered key locks
- Horizontal handles
- Self-adjusting magnetic gaskets

REFRIGERATION

- Top mounted, self-contained refrigeration system
- Refrigerant: R-134a
- Automatic defrost
- Automatic energy efficient hot gas condensate evaporator
- Refrigerant controlled by capillary tube
- Minimum 4" clearance required on top, rear and sides of cabinet
- Temperature range: 34° to 41°F (1° to 5°C)

WARRANTY

- Standard limited three year extended compressor and two year limited parts and labor

TECHNICAL SPECIFICATIONS

MODEL	DIMENSIONS (in.)			DIMENSIONS (mm)			VOLTS*	AMPS	UNIT H.P.	NO. OF DOORS	CAP. CU. FT.	SHIP CU. FT.	SHIP WT. LB/KG
	L	D	H	L	D	H							
MPWR332	31 ³ / ₄	39 ³ / ₈	84 ³ / ₄	806	1000	2153	115	7.7	1/3	2	33.0	82.0	596/271
MPWR724	63 ¹ / ₂	39 ³ / ₈	84 ³ / ₄	1613	1000	2153	115/208-230	10.4	3/4	4	72.0	154.9	690/314

*MPWR724 operates on a minimum of 208 volts. A voltage boosting transformer (part no. 39-01087) must be used when the supply voltage is less than 208 volts.

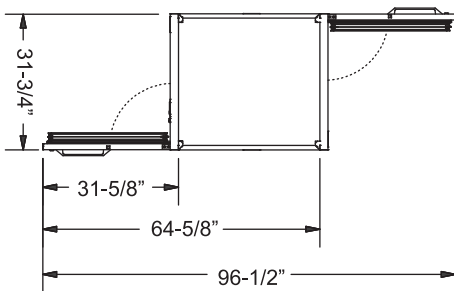

MPWR332 PLAN VIEW

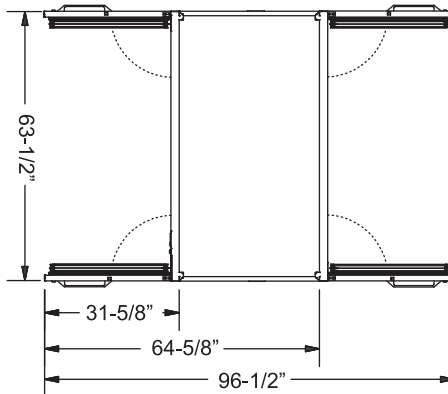

MPWR724 PLAN VIEW

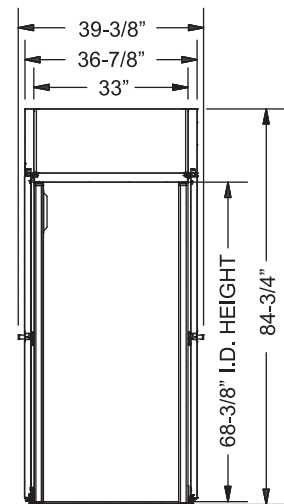

SIDE VIEW - BOTH

LISTINGS



HOOKUP

MPWR332: Via plug in, 10 foot long flexible three wire 14/3 cord with molded plug.

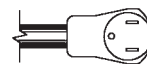

NEMA 5-15P (MPWR332 model)

MPWR724: Via plug in, 10 foot long flexible four wire 208-230v 12/4 cord with neutral and ground wires and molded plug.

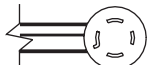

NEMA L14-20P (MPWR724 model)

BID SPECIFICATIONS

Item no. MPWR _____
Provide _____ () Roll-Thru Refrigerator(s), Master-Bilt model no. MPWR _____.

Roll-thru refrigerator will be equipped with an electronically controlled monitoring system. The exterior front, sides and doors will be stainless steel while the exterior top, bottom and back will be galvanized steel. The interior liner and door

panel will be stainless steel. An interior LED light activated by switches for each door and a digital thermometer.

Doors will feature heavy-duty pivot hinges and centered key locks with horizontal handles.

The refrigeration system will be top mounted and self-contained. The refrigerant will be R-134a and the temperature range will be 34° to 41°F (1° to 5°C). The

refrigeration system will also feature automatic defrost and an automatic energy efficient hot gas condensate evaporator. Refrigerant will be controlled by capillary tube.

Roll-thru to have standard limited three year extended compressor warranty and two year limited parts and labor warranty.

Roll-thru to be UL and C-UL listed and UL EPH classified.

NOTE: Cabinet designed for optimum performance in air-conditioned area at 75°F ambient and 55% relative humidity. All specifications subject to change without notice.