



TLG-48HD

TLG SERIES

Top Mounted Low Temp Glass Door Merchandisers

MODELS

- TLG-27HD
- TLG-48HD
- TLG-52HD
- TLG-74HD
- TLG-80HD



ENERGY STAR® qualified models feature highly efficient compressors, generously-sized condensers and evaporators and EC evaporator motors. These models may also qualify for energy rebate programs.

FEATURES

STANDARD TEXTURED FINISH



Standard white

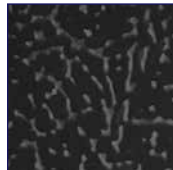

Black also available

- Equipped with standard LED lighting for greater energy efficiency
- 6"-7" adjustable metal legs
- Five white epoxy-coated, heavy-duty welded wire shelves (four cantilever, one bottom) with price tag molding per door
- Cantilever shelves are two-position and adjustable in 1" increments
- Independent on/off light switch
- 2" foamed-in-place "zero ODP" urethane insulation

- Temperature range: 5° to -15°F (-18° to -26°C)
- R-factor (insulation efficiency rating): 17.24

WARRANTY

- Standard limited two year parts and labor
- Additional three year coverage on compressor part

CONSTRUCTION

- Standard electronic controller with these features:
 - Ability to monitor defrost functions from the front panel interface
 - Audible and visual alarm
 - Eliminates room thermostat, defrost termination/fan delay control, defrost timer and digital thermometer or other temperature indicator
- 24 gauge painted textured galvanized steel interior and exterior
- Single cord and plug standard on all self-contained models
- Replaceable magnetic vinyl door gaskets

DOORS

- Extra large, auto-close, triple pane, with heated safety glass and heated frames
- Black door rails and handles
- Adjustable torsion bar hinges
- Door hinges easily adjustable for closing tension and leveling

REFRIGERATION

- Self-contained, factory tested, slide out refrigeration system
- Electric condensate evaporator
- Top mounted low profile interior fan housing
- Refrigerant: R-404A

OPTIONS

- Add suffix "R" for remote system (available on TLG-48HD and TLG-74HD only)
- Add suffix "QC" for quick couple system
- Custom exterior colors
- Baskets
- Extra shelves
- Voltage boosting transformer
- Casters



TLG SERIES

TOP MOUNTED LOW TEMP GLASS DOOR MERCHANDISERS

TECHNICAL SPECIFICATIONS

MODEL	DIMENSIONS (in.)			DIMENSIONS (mm)			VOLTS**	AMPS	UNIT H.P.	NO. OF DOORS	CAP. CU. FT.	SHIP CU. FT.	SHIP WT. LB/KG
	L	D	H*	L	D	H							
TLG-27HD	31	35 ³ / ₄	85	787	908	2159	115	11.1	3/4	1	27.5	79.0	600/273
TLG-48HD	52	35 ³ / ₄	85	1321	908	2159	208-230	8.8	1 ¹ / ₂	2	49.0	118.7	830/377
TLG-52HD	56	35 ³ / ₄	85	1422	908	2159	208-230	8.8	1 ¹ / ₂	2	53.0	128.0	850/386
TLG-74HD	78	35 ³ / ₄	85	1981	908	2159	208-230	10.0	2	3	75.5	168.0	1085/493
TLG-80HD	84	35 ³ / ₄	85	2134	908	2159	208-230	10.0	2	3	81.6	185.0	1100/500

*Height includes 6"-7" adjustable legs. **TLG models (except TLG-27HD) operate on a minimum of 208 volts. A voltage boosting transformer (part no. 39-01087) must be used when the supply voltage is less than 208 volts. **Note: 208-230/60/1 also requires neutral and safety ground wire.**

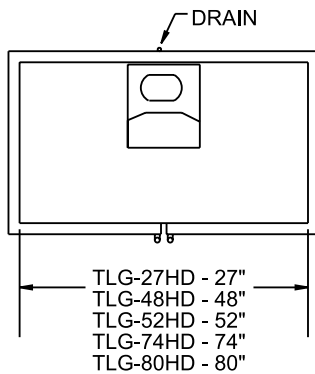

PLAN VIEW

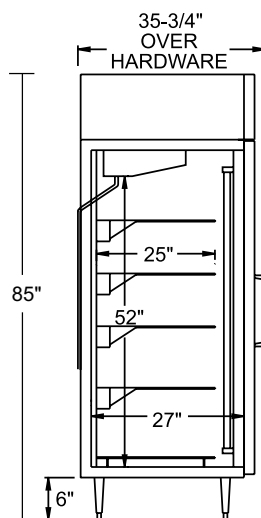

SIDE VIEW

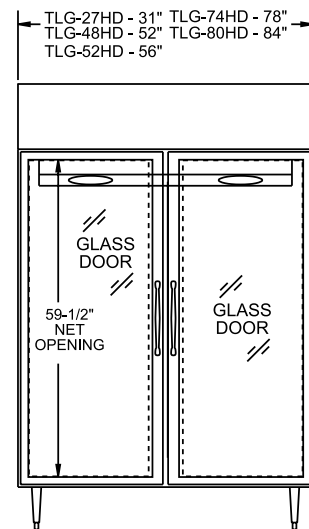

ELEVATION VIEW

LISTINGS



HOOKUP

TLG-27HD: Via plug in, 9 foot long flexible three wire 14/3 cord with molded plug.

Other models: Via plug in, 9 foot long flexible four wire 208-230v 14/4 cord with neutral and ground wires and molded plug.

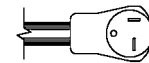

NEMA 5-20P (TLG-27HD ONLY)

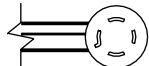

NEMA L14-20P (ALL OTHER MODELS)

BID SPECIFICATIONS

Item no. TLG-_____HD.
Provide _____ () Top Mounted Low Temp Glass Door Merchandiser(s), Master-Bilt model no. TLG-_____HD.

Merchandiser will feature textured finish on interior and exterior and will be equipped with an electronically controlled monitoring system. Energy efficient LED interior lighting will be standard. It will also be provided with a top mounted low

profile interior fan housing, electric condensate evaporator, rear wall guard and metal legs with 6"-7" adjustable range. Five white epoxy-coated shelves (four cantilever and one bottom) with price tag molding per door will be standard.

Doors will contain black rails and handles, triple pane glass, adjustable torsion-bar hinges and heated frames and door openings.

The refrigeration system will be top

mounted, self-contained and use R-404A refrigerant. The temperature range will be 5° to -15°F (-18° to -26°C).

Merchandiser to have standard limited two year parts and labor with additional three year coverage on compressor part.

Merchandiser to be UL, C-UL and NSF listed as well as ENERGY STAR qualified.

NOTE: Cabinet designed for optimum performance in air-conditioned area at 75°F ambient and 55% relative humidity. All specifications subject to change without notice.



908 Highway 15 North • New Albany, MS 38652

PHONE: 800-647-1284 or 662-534-9061 • FAX: 800-232-3966 or 662-534-6049 • www.master-bilt.com

