

- Designed by beer-industry experts for performance and value.
- Integrated glass rinser: condition the glass with cold water before pouring.
- Rugged keg slides – extends floor life.
- Full-size drain tray – larger work area and improved hygiene.



▶ Integrated cold water glass rinser.



Black with Glass Rinser

**MDD23-GR**



Stainless Steel with Glass Rinser

**MDD23S-GR**

## Feature



Listed by Edison Testing Laboratories.  
Conforms to UL & NSF Standards.

Part No.	Exterior Finish	Doors	Shipping Weight	Box Dimensions
☐ <a href="#">MDD23-GR</a>	Black With Glass Rinser	1	78 kg	679mm L x 794mm W x 1194mm H
			171 lbs	26 3/4"L x 31 1/4"W x 47"H
☐ <a href="#">MDD23S-GR</a>	Stainless Steel With Glass Rinser	1	78 kg	679mm L x 794mm W x 1194mm H
			171 lbs	26 3/4"L x 31 1/4"W x 47"H

## Operating Performance

<b>Capacity of 1/2 Kegs</b>	1	<b>Running Amps</b>	2.7
<b>Cubic Feet (liters)</b>	8.4 (239)	<b>Voltage</b>	115/60/1
<b>Number of Draft Towers</b>	1	<b>Plug Type</b>	NEMA-5-15P
<b>Number of Faucets</b>	1	<b>Cord Length</b>	8'
<b>Beer Tower Approval</b>	NSF 7.0 and NSF 18	<b>Refrigerant</b>	R-134a
<b>Approval</b>	ETL Listed	<b>Charge oz (Grs)</b>	10.5 (300)
<b>Condenser HP</b>	1/6		

<b>Exterior</b>	All Models: 18 gauge stainless steel top, 22 gauge solid doors, 24 gauge steel front, sides and back. Black Vinyl Models: Front, sides. Stainless Steel Models: Front, sides.
<b>Interior</b>	20 gauge stainless steel floor, reinforced frame, 24 gauge galvanized walls
<b>Ventilation</b>	Back ventilated
<b>Plumbing</b>	Drain Tray: 3/4" NPT drain exits out left end. Automatic condensate evaporator, no drain connection required. Evaporator condensate has been plumbed to a condensate pan located in the compressor housing.
<b>Insulation</b>	Foamed-in-place using high density, CFC-free polyurethane; 1-1/2" top, walls and floor.
<b>Castors</b> - Standard	
<b>Glass Rinser</b>	15 - 20 PSI Water Connection

## Dimensions

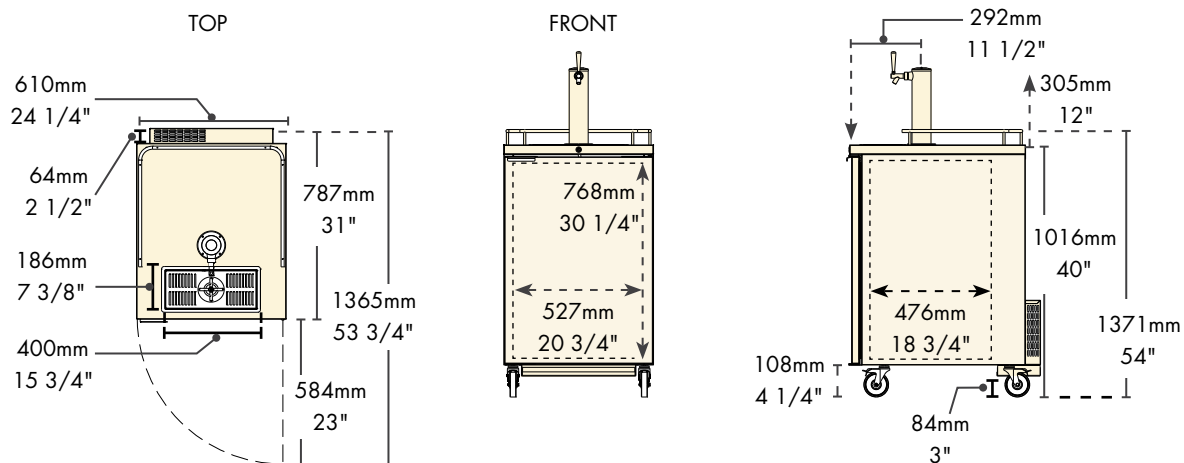

Copyright ©2012 Micro Matic USA, Inc. All Rights Reserved. 00463.D0312



[www.micromatic.com](http://www.micromatic.com)

Toll Free: 1-(866) 327-4159

West	Central	Southeast	Northeast
19791 Bahama Street Northridge, CA 91324 Tel. (818) 701-9765 Fax. (818) 701-9844	10726 North Second Street Machesney Park, IL 61115 Tel. (815) 968-7557 Fax. (815) 968-0363	2364 Simon Court Brooksville, FL 34604 Tel. (352) 799-6331 Fax. (352) 796-2429	4601 Saucon Creek Road Center Valley, PA 18034 Tel. (610) 625-4464 Fax. (610) 625-4466