

- Engineered by beer-industry experts for performance and value.
- Digital thermostat for accurate glycol bath temperature.
- Insulated cabinet maintains glycol temperature while minimizing condensation.
- Exterior sight glass to verify glycol bath level.

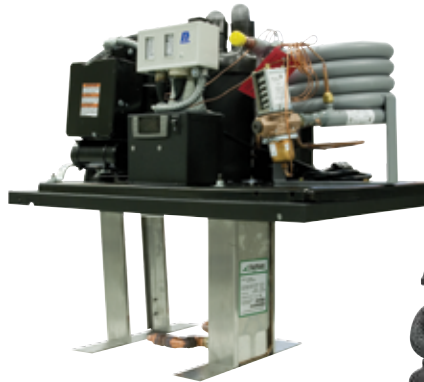

MMPP4305-PKG



MMPP4305-PKG-WC



Feature

 ETL Listed.

Specifications

Micro Matic reserves the right to change specifications without notice. **AUTOQUOTES**

Part No.	Description	Shipping Weight	Box Dimensions
<input type="checkbox"/> MMPP4305-PKG	Air Cooled	98 kg 215 lbs.	1016mm L x 635mm W x 1041mm H 40"L x 25"W x 41"H
<input type="checkbox"/> MMPP4305-PKG-WC	Water Cooled	98 kg 215 lbs.	1016mm L x 635mm W x 1041mm H 40"L x 25"W x 41"H

Compressor	1 HP
BTU per hour	7,200
Plug Type (NEMA #)	6-15P
Voltage	208/230
Running	11A
Refrigerant	R-134a
Charge	.45 kg (20 oz)
Bath Capacity	43.5 litre (11.5 Gallons)
Pump Type	Gear
Inlet Barb:	9.52mm (3/8")
Outlet Barb:	9.52mm (3/8")

Water Cooled Model	
Water Inlet & Outlet Fitting	Female 3/8" NPT
Minimum Water Pipe Size	3/8"
Inlet Water Pressure	Less than 80 PSIG
Water Usage	.98 GPM Water is only used when the temperature of the condenser rises high enough to open the cooling inlet valve. This is approximately 40% of the operating time depending on ambient temperature and usage.
Condenser Inlet Water Temperature	75° F
Maximum Outlet Water Temperature	95° F (to minimize water scaling within the condenser).

Dimensions

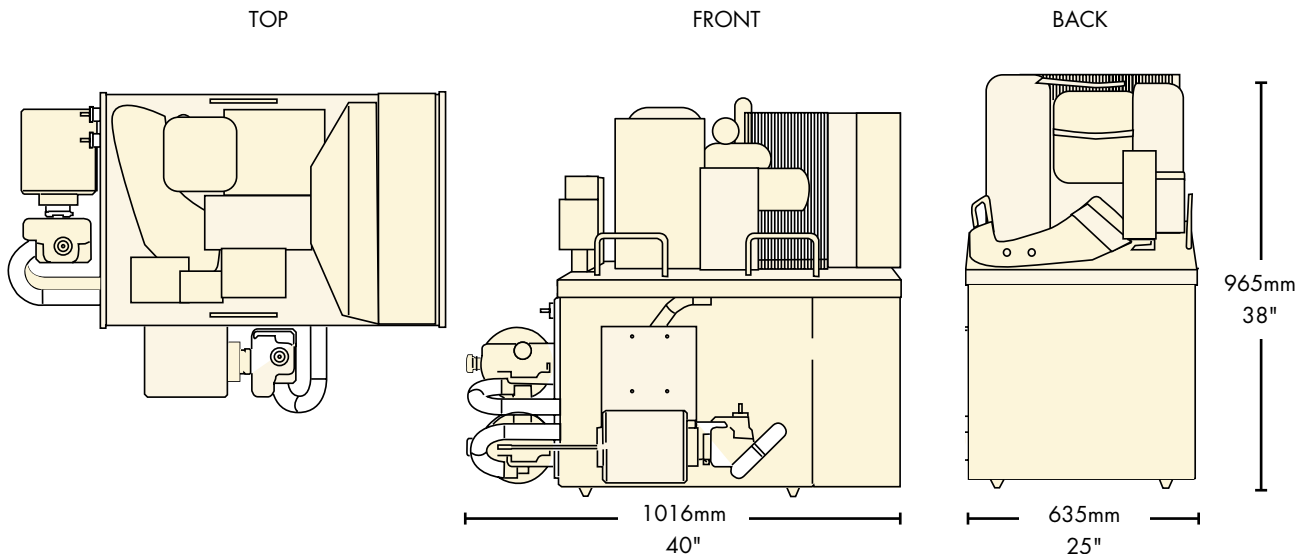

Copyright ©2011 Micro Matic USA, Inc. All Rights Reserved.

00099D0410



www.micromatic.com

Toll Free: 1-(866) 327-4159

West	Central	Southeast	Northeast
19791 Bahama Street Northridge, CA 91324 Tel. (818) 701-9765 Fax. (818) 701-9844	10726 North Second Street Machesney Park, IL 61115 Tel. (815) 968-7557 Fax. (815) 968-0363	2364 Simon Court Brooksville, FL 34604 Tel. (352) 799-6331 Fax. (352) 796-2429	4601 Saucon Creek Road Center Valley, PA 18034 Tel. (610) 625-4464 Fax. (610) 625-4466