



LEGEND™

Hearthbake Double Deck Gas Pizza Ovens

Item No. _____

Project _____

Quantity _____



Model 24P-2 Shown with standard stainless steel front and 15" (381 mm) gusset-style legs.

SHORT/BID SPECIFICATION

Double deck oven shall be a Montague Legend *Hearth Bake* Model [Specify one]:

- 23P-2**, a 62" (1575mm) wide unit with two gas 40,000 BTU/hr burners mounted below each 41-1/2" x 31" (1054 x 787mm) Cordierite baking hearth/deck
- 24P-2**, a 69" (1753mm) wide unit with three gas 40,000 BTU/hr burners mounted below each 48-1/2" x 36" (1232 x 914mm) Cordierite baking hearth/deck
- 25P-2**, an 81" (2057mm) wide unit with four gas 40,000 BTU/hr burners mounted below each 60-1/2" x 36" (1537 x 914mm) Cordierite baking hearth/deck

...with fire brick lined cooking compartments, thick blanket insulation and modulating thermostats; heavy-duty counter-weighted drop down doors, satin finished stainless steel front and doors, sides and top, plus 15" (381mm) stainless steel legs and black painted top-mounted flue deflector standard; plus all the features listed and options/accessories checked:

OVEN INTERIOR CONSTRUCTION [EACH DECK]:

- Two 8" (203 mm) high bake compartments
- 1-1/2" (38 mm) thick Cordierite decks for true Hearth Bake results
- Oven sides, back and tops are lined with fire brick
- High temperature fiberglass blanket insulation

BURNERS & CONTROLS [EACH DECK]:

- Removable long life cast iron 40,000 BTU/hr burners
- Adjustable air shutters with position lock
- 300-650°F (148-343°C) burner-modulating thermostat
- Burners & standing pilot accessed through fire door with crumb ejector
- Automatic safety pilots for automatic ignition

MODEL-PRODUCTION GUIDE			CAPACITY*	
Model No.	Overall Width	Deck Size	12" (305 mm)	18" (457 mm)
23P-2	62" (1575mm)	41-1/2" x 31" (1054 x 787mm)	6 ea.	2 ea.
24P-2	69" (1753mm)	48-1/2" x 36" (1232 x 914mm)	8 ea.	4 ea.
25P-2	81" (2057mm)	60-1/2" x 36" (1537 x 914mm)	10 ea.	6 ea.

*Production, Per Deck

EXTERIOR CONSTRUCTION FEATURES:

- Satin finish stainless steel front, two sides and top
- Other surfaces painted black with electrolytic zinc undercoating
- 7-3/4" (197mm) high flue deflector standard
- Full compartment width drop-down doors with aluminized steel interiors
- Doors are counterweighted for tight seal and easy closing (no springs)
- One piece tubular offset-mounted door handles
- 15" (381mm) stainless steel clad legs with adjustable bullet feet standard
- (2) 3/4" NPT rear gas connection

AGENCY APPROVALS

- NSF Listed
- CSA Design Certified to ANSI Z83.11 • CSA 1.8



DO-2 [Rev. 1/13]

Item No. _____

Project _____

Quantity _____

LEGEND™ Hearthbake Double Deck Gas Pizza Ovens

Dimensions in brackets are millimeters

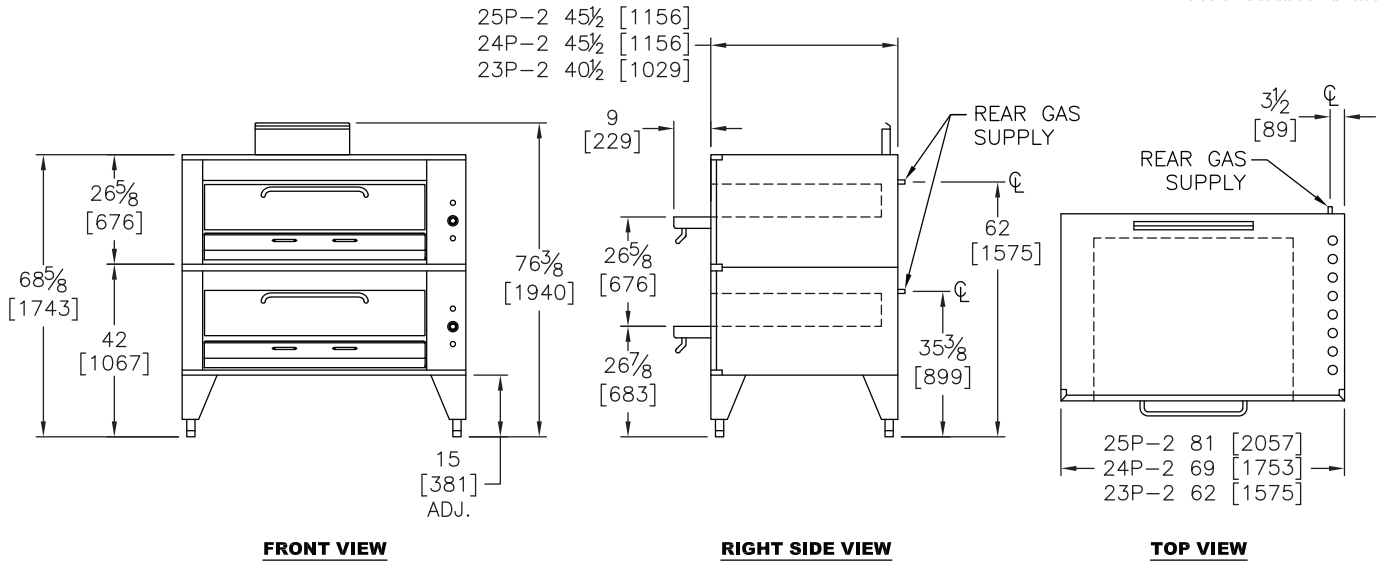

OPTIONS GUIDE:

Oven Interior:

- Fire brick baking hearth

Installation Alternatives:

- Downdraft diverter [in lieu of flue deflector for direct flue connection, codes permitting]
- Stainless Steel Black Painted
- Manifold assembly for single gas inlet- 1"NPT

Exterior Finish:

- Stainless steel back panel
- For custom exterior decors. Consult Factory.

INSTALLATION REQUIREMENTS & SHIPPING INFORMATION

- Ovens must be installed in accordance with local codes or in their absence with the National Fuel Gas Code: ANSI Z223.1; Natural Fuel Gas Code: CAN/CGA-B149.1 or Propane Installation Code: CAN/CGA-B149.2, as applicable. Compliance with codes is the responsibility of the Owner and Installer.
- An adequate ventilation system is required. Refer to National Fire Protection Association Standard No. 96, "Standard for Ventilation and Fire Protection of Commercial Cooking Operations."
- This appliance is intended for commercial use by professionally trained personnel. NOT intended for Residential Use.
- Specify installation elevation:** _____ if above 2000 feet (610m).
- GAS INLET SIZE (All Models):** Two 3/4" NPT gas connections provided at left-rear. Two 3/4" NPT gas pressure regulators are provided and must be installed (by others) when unit is connected to gas supply.
- The incoming gas line pressure into the regulator should be 8"-14" w.c. for natural gas, and 12"-14" w.c. for propane gas.

Minimum Clearances	Combustible Construction	Noncombustible Construction
From Back Wall	3" (76mm)	3" (76mm)
Left & Right Side	1" (25mm)	0"
With 15" (381mm) legs	Suitable for installation on combustible floors	

Specify Type of Gas:		<input type="checkbox"/> Natural		<input type="checkbox"/> Propane		Shipping Weight	Shipping Class	Cube (Crated) ft³/m³
Models:	Burners	Manifold Pressure	BTU/hr* (kW)	Manifold Pressure	BTU/hr* (kW)			
23P-2	4	4.4" WC	160,000 (46.9)	10" WC	160,000 (46.9)	1912 lbs (866 kg)	85	112/3.1
24P-2	6	3.5" WC	240,000 (70.3)	10" WC	240,000 (70.3)	2560 lbs (1160 kg)	85	138/3.9
25P-2	8	3.1" WC	320,000 (93.8)	10" WC	320,000 (93.8)	3500 lbs (1586 kg)	85	174/4.9

*Total for both decks

*Top fire brick and deck material ship in two cartons. Entry Clearance: 27" (686mm) uncrated.

Due to continuous product improvements, specifications are subject to change without notice.



THE MONTAGUE COMPANY

1830 Stearman Avenue, Hayward, CA 94545
 800 345-1830 • Fax: 510 785-3342
 www.montaguecompany.com



DO-2 [Rev. 1/13]