



VECTAIRE™ Full-Size, Standard Depth Electric Convection Ovens

Item No. _____

Project _____

Quantity _____

EK12A Series



Model EK12A shown with optional casters

SHORT/BID SPECIFICATION

Convection oven shall be a Montague *Vectaire* full-size electric Model

- EK12A a single standard depth 12-kW unit with 24" (610mm) black painted, gusset-style legs

...with three tubular heating elements in one group of three; a porcelainized steel oven interior with two-speed standard fan, nine rack positions, five bright nickel racks with rack stops and no-tip guides standard; two 50-50 stainless steel doors with double pane viewing windows; plus all the features listed and options/accessories checked:

OVEN INTERIOR CONSTRUCTION:

- Porcelainized steel cooking compartment
- Nine-position bright nickel rack guides
- Five bright nickel pan racks, with rack-stop and no-tip guides standard
- Two compartment interior lights
- 4" (102mm) of insulation compressed to 2" (51mm) with metal sheathing

HEATING ELEMENTS & BLOWER SYSTEM:

- Three 3.744-kW heating elements grouped in one set
- Blower with 1/2-horsepower two-speed motor

MODEL-PAN/RACK GUIDE:

✓	Model No.	Oven Depth	Racks/Positions	Rack Spacing	
				5-racks	9-racks
	EK12A	Standard	5/9	3-3/8" (86mm)	1-1/2" (38mm)

EXTERIOR CONSTRUCTION FEATURES:

- Satin finish stainless steel front, sides and top
- Black painted steel back and legs
- Access hole in back of unit and a 1" (25mm) knock-out at connection point
- Ball bearing mounted 50-50 double door
- Double pane thermal viewing windows
- Tubular grab-bar handle with insulated comfort grip
- Durable, adjustable door gasket
- 24" (610mm) legs gusset-style legs with adjustable bullet feet

CONTROL FEATURES:

- Power/fan speed control (two speed fan)
- Power indicator light
- Momentary-ON interior light switch
- Snap-action electric thermostat with 200-500°F (93-260°C) range
- Burner indicator light
- 60-minute electric countdown timer with alarm
- Moisture vent

AGENCY APPROVALS

- NSF Listed
- UL Listed (ANSI/UL-197)



VC0-17 [Rev. 1/13]

VECTAIRE™ Full-Size Standard Depth Electric Convection Ovens

Item No. _____

Project _____

Quantity _____

EK12A

Dimensions in brackets are millimeters

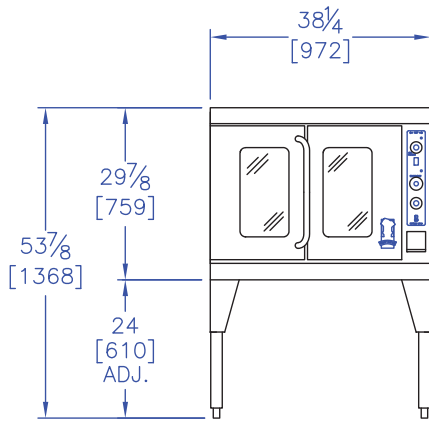

FRONT VIEW

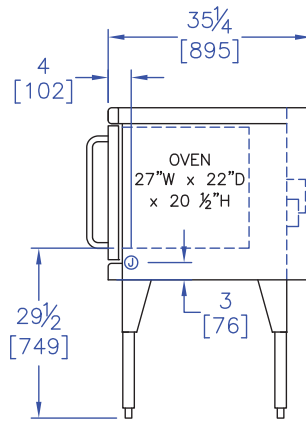

RIGHT SIDE VIEW

⊙ DENOTES 1" DIA. KNOCKOUT FOR FIELD SUPPLY CONNECTION

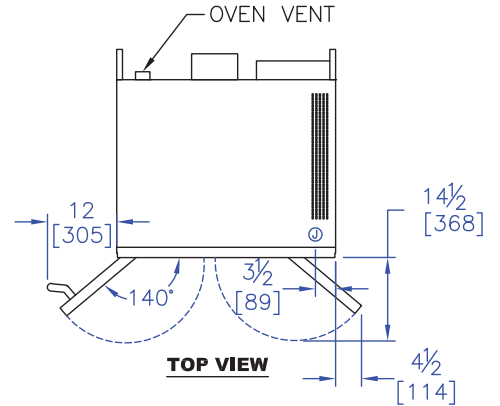

TOP VIEW

OPTIONS GUIDE:

Installation Alternatives:

- Stacking Kit (for bottom unit)
- Stem Casters 5" (127mm) for use with Gusset-style legs
- Modular Stand [open base] with 4" (102mm) frame, stainless steel front, lower shelf and 19-1/2" (495mm) stainless steel legs
 - 3-1/2" (89mm) stem casters
 - 9-position removable pan slides (for stand)

Finish:

- Full stainless steel oven interior [-ASC suffix]
- Stainless steel louvered back panel
- 24" (610mm) Stainless steel gusset-style legs
- Stainless steel exterior bottom

Electric, Controls & Motor Alternatives:

- Solid state thermostat

Racks & Security:

- Stainless steel drip tray
- Extra Racks: _____ ea. std.; _____ ea. heavy duty
- 11-position rack guides [set of two]
- Solid Doors [in place of windows]
- Security Options [Consult Factory]
- Independent doors

INSTALLATION REQUIREMENTS & SHIPPING INFORMATION

- Oven must be installed in accordance with local codes or in their absence with the National Electric Code: ANSI/NFPA 70. Compliance with codes is the responsibility of the Owner and Installer.
- An adequate ventilation system is required. Refer to National Fire Protection Association Standard No. 96, "Vapor Removal from Cooking Equipment."
- This appliance is intended for commercial use by professionally trained personnel. NOT intended for Residential Use.

Minimum Clearances	Combustible Construction	Noncombustible Construction
From Back Wall	0"	0"
Left & Right Side	0"	0"
Unit must be mounted on legs.		

Electric Requirements*

Voltage	Phase	Hz	Total kW	Nominal AMP/Line			Minimum Circuit Capacity
			EK12A	L1	L2	L3	
208	1	60	12.00	57			72
240	1	60	12.00	50			63
208	3	60	12.00	34	34	31	43
240	3	60	12.00	30	30	27	40
480	3	60	12.00	17	17	14	22

*Other Voltage/Hz models available. Contact factory.

Shipping Information:

Models	Weight	Shipping Class	Cube (Crated) ft ³ /m ³
EK12A [all]	435 lbs (197 kg)	70	37/1
Modular Stand w/shelf	add 78 lbs (35 kg)	70	21/.6
Entry clearance 30" (762mm) uncrated			



THE MONTAGUE COMPANY

1830 Stearman Avenue, Hayward, CA 94545
 800 345-1830 • Fax: 510 785-3342
 www.montaguecompany.com

Due to continuous product improvements, specifications are subject to change without notice.



KCO-17 [Rev. 1/13]