



VECTAIRE™ Single Deck, Full-Size Gas Convection Oven

Item No. _____

Project _____

Quantity _____

HX-63 Series



Model HX-63A

SHORT/BID SPECIFICATION

Single Deck convection oven shall be a Montague **Vectaire** Model [Specify one]:

- HX-63A**, with standard HX Controls including: individual solid state 200-500°F (93-260°C) thermostat, 60-minute electric countdown timer with alarm and burner-ON indicator light
- HX-63AH**, with Cook-n-Hold Controls including: individual solid state 150-500°F (66-260°C) thermostat, 24-hour digital countdown timer with alarm, programmable HOLD feature and burner-ON indicator light

...plus Vectaire stainless steel heat exchanger with 63,000 BTU/hr power input and electronic ignition; a porcelainized steel oven interior with two speed fan, nine rack positions, five bright nickel racks with rack stops and no-tip guides standard; ball bearing mounted 50-50 split doors with double pane viewing windows; plus all the features listed and options/accessories checked:

OVEN INTERIOR CONSTRUCTION:

- Porcelainized 16-gauge steel interior
- 27" (686mm)(Bakery Depth) interior accepts pans lengthwise or sideways
- Nine-position bright nickel rack guides
- Five bright nickel pan racks, with rack-stop and no-tip guides standard
- 4" (102mm) of insulation compressed to 2" (51mm) with metal sheathing
- Two covered interior lights

MODEL-PAN/RACK GUIDE:

✓ Model No.	Racks/ Positions	Pan Loading*		Rack Spacing	
		Length	Sideways	5-racks	9-racks
HX-63A	5/9	yes	yes	3-3/8" (86mm)	1-1/2" (38mm)
HX-63AH	5/9	yes	yes	3-3/8" (86mm)	1-1/2" (38mm)

*18" x 26" (477 x 660mm) sheet pans

BURNERS & BLOWER SYSTEMS:

- Indirect-heated "muffled oven" design
- Stainless steel burners with 63,000 BTU/hr output
- High efficiency sealed stainless steel heat exchanger
- Burner pilot with dependable electronic ignition
- Blower with 1/2-horsepower two-speed motor

EXTERIOR CONSTRUCTION FEATURES:

- Satin finish stainless steel front, sides and top
- Aluminized steel back and flue deflector with stainless front-trim
- Ball bearing mounted 50-50 split double doors
- Double pane, thermal viewing windows
- Single vertical grab handle opens both doors
- Black painted-steel gusset-type legs, with adjustable bullet feet
- 6' (1829mm) power cord with grounded NEMA 5-15P plug

CONTROL FEATURES:

- Power/Fan speed control (two-speed fan)
- Automatic fan cutoff when door is opened (except in cool-down)
- Momentary-ON interior light switch
- Burner-ON indicator light
- Standard — A Package:**
 - Solid state 200-500°F (93-260°C) thermostat
 - 60-minute electric countdown timer with alarm
- Cook-n-Hold — AH Package:**
 - Solid state 150-500°F (66-260°C) thermostat
 - 24-hour digital countdown timer with alarm
 - Programmable HOLD feature
 - Intermittent Fan Operation (IFO)

AGENCY APPROVALS

- NSF Listed
- CSA Design Certified to ANSI Z83.11 • CSA 1.8
- ENERGY STAR qualified



VCO-1 [Rev. 1/13]

VECTAIRE™ Single Deck, Full-Size Gas Convection Oven

Item No. _____

Project _____

Quantity _____

HX-63 Series

Dimensions in brackets are millimeters

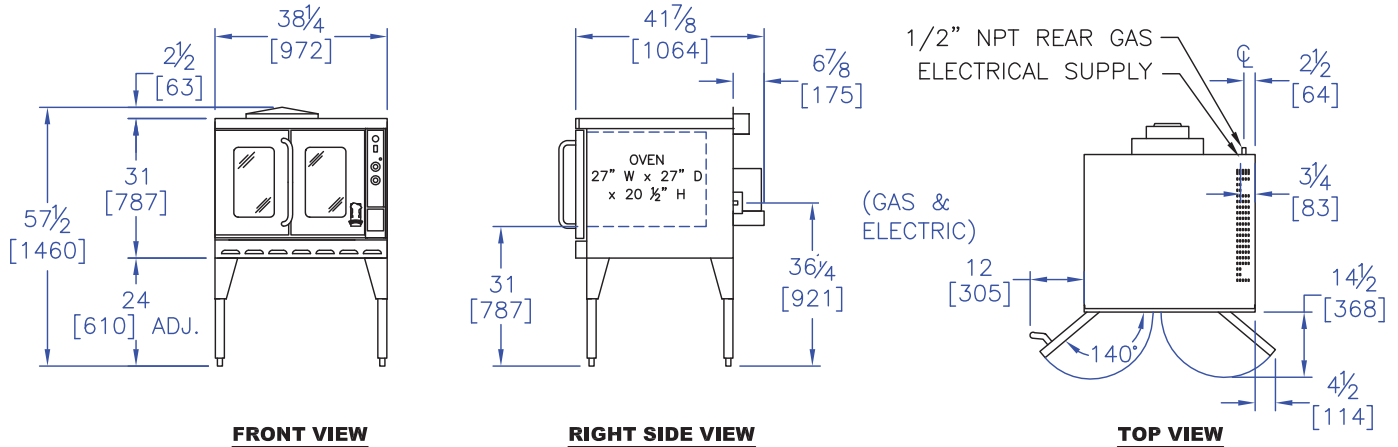

OPTIONS GUIDE:

Installation Alternatives:

- Stacking Kit (for bottom unit):
- Flexible gas quick-disconnect kit [with restraint]
- Stem casters for gusset-style legs; set of 4 ea., 5" (127mm)
- Stainless steel downdraft diverter
- Modular Stand (open base) with 4" (102mm) frame, stainless steel front, sides and lower shelf, tubular 19-1/2" (495mm) legs, plus:
 - Stem casters 3-1/2" (89mm)
 - 9-position removable pan slides for stand
 - Side and back to match oven
 - Heat shield kit-[See minimum clearances]

Electric, Controls & Alternatives

- 120-volt, 1-Phase, 60 Hz, 7.2 AMP [w/6' (1.8m) power cord]
- 208-240-Volt, 1-Phase, 60 HZ, 2.9 AMP
- For 208-240-Volt, 3-phase [Consult Factory]
- 3/4-Horsepower reduced depth blower motor

Finish:

- Full stainless steel oven interior [-ASC suffix]
- Stainless steel back panel
- Stainless steel flue deflector
- Stainless steel gusset-type legs
- Stainless steel exterior bottom
- Stainless steel louvered back panel

Racks & Security:

- Stainless steel drip tray
- Extra Racks: ____ ea. std. ____ ea. heavy duty
- 11-position rack guides [set of two]
- Security Options [Consult Factory]
- Solid Doors [in place of windows]

INSTALLATION REQUIREMENTS & SHIPPING INFORMATION

- Ovens must be installed in accordance with local codes or in their absence with the National Fuel Gas Code: ANSI Z223.1; Natural Fuel Gas Code: CAN/CGA-B149.1 or Propane Installation Code: CAN/CGA-B149.2, as applicable. Compliance with codes is the responsibility of the Owner and Installer.
- An adequate ventilation system is required. Refer to National Fire Protection Association Standard No. 96, "Standard for Ventilation and Fire Protection of Commercial Cooking Operations."
- This appliance is intended for commercial use by professionally trained personnel. NOT intended for Residential Use.
- Specify installation elevation:** _____ if above 2000 feet (610m).
- GAS INLET SIZE (All Models):** One 1/2" NPT gas connections provided at left-rear. One 1/2" NPT gas pressure regulators are provided and must be installed (by others) when unit is connected to gas supply.
- The incoming gas line pressure into the regulator should be 8"-14" w.c. for natural gas, and 12"-14" w.c. for propane gas.

Minimum Clearances	Combustible Construction	Noncombustible Construction
From Back Wall	7" (178mm)	7" (178mm)
Left & Right Side*	6" (152mm)	0"
With 24" (610mm) legs	Suitable for installation on combustible floors	
*HX Vectaire spacing to adjacent units require 6" (152mm) minimum clearance on right side between similar ovens or other cooking equipment. Optional heat shield kits reduce the clearance required between similar ovens to 1" (25mm) and 2" (51mm) from other cooking equipment.		

Specify Type of Gas:		<input type="checkbox"/> Natural	<input type="checkbox"/> Propane	Shipping Weight	Shipping Class	Cube (Crated) ft ³ /m ³
Gas Delivery Pressure:		3.5" WC	10.0" WC			
Models:	Burners	BTU/hr (kW)	BTU/hr (kW)			
HX-63 [all]	1	63,000 (18.5)	63,000 (18.5)	500 lbs (227 kg)	70	34/.9
With modular stand add:				78 lbs (35 kg)	70	21/.6
Entry Clearance: 31-1/2" (800mm) uncrated						

Due to continuous product improvements, specifications are subject to change without notice.



THE MONTAGUE COMPANY

1830 Stearman Avenue, Hayward, CA 94545
 800 345-1830 • Fax: 510 785-3342
 www.montaguecompany.com



VCO-1 [Rev. 1/13]