



LEGEND™ Heavy-Duty Gas Underfired Broilers — Ceramic Free-Standing Cabinet Base

Item No. _____

Project _____

Quantity _____

UFS-C Series



Model UFS-36C shown, with optional lower warming-finishing rack

SHORT/BID SPECIFICATION

Broiler shall be a Montague Legend Heavy-Duty Free-Standing Cabinet Base Model:

UFS- ____ C [Specify width]

...a gas-fired unit with efficient 45,000 BTU/hr cast iron 'H' burners with individual controls, ceramic briquettes, and full width debris screen under burners; two-position, reversible cast-iron ULTRA-FLOW top grates with both flat (wide) and narrow sides with ribbed grease troughs; three-position rear grate with lift mechanism; a full width front grease trough and large capacity grease container located in cool zone; 4-1/2" (114mm) front/plate rail, 5-9/16" (141mm) high side and rear grease splash, mounted on a stainless steel cabinet base with 6" (152mm) legs as standard; plus all the features listed and options/accessories checked:

BURNER/CERAMIC BED FEATURES:

- 45,000 BTU/hr cast iron 'H' burners
- Stainless steel drip shields;
- Individual manual gas valves for zoned heat control
- Standing pilot for automatic ignition.
- Quick heat absorbing ceramic briquettes reduces flare-ups
- Full width debris screen under burners and above;
- Full width removable trip tray.

TOP-GRATE FEATURES:

- Reversible ULTRA-FLOW cast iron grate sections
- Ribbed side for narrow marking, with side grease troughs
- Flat side for broiling fish and wide marking
- 1" (25mm) ribbed grate spacing for consistent grilling results
- Three-position grid frame for adjustment from flat to 3" (76mm) raised-rear
- Three position easy-lift grate mechanism
- Sloped grates and side grate grease troughs to reduce flare-ups

MODEL GUIDE

✓ Model No.	Overall Width	Grates	Cooking Area
UFS-24C	24" (610mm)	3	18" x 24" (457 x 610mm)
UFS-30C	30" (762mm)	4	24" x 24" (610 x 610mm)
UFS-36C	36" (914mm)	5	30" x 24" (762 x 610mm)
UFS-48C	48" (1219mm)	6	36" x 24" (914 x 610mm)
UFS-60C	60" (1524mm)	8	48" x 24" (1219 x 610mm)
UFS-72C	72" (1829mm)	10	60" x 24" (1524 x 610mm)

STANDARD CONSTRUCTION FEATURES:

- Satin finish stainless steel front & top trim with 4-1/2" (114mm) deep front rail
- 5-9/16" (141mm) high stainless steel side and rear splash
- Enclosed cabinet base with 6" (152mm) adjustable stainless steel legs
- Other surfaces painted black with electrolytic zinc undercoating
- Full width front grease trough for easy transfer
- Removable large capacity grease container.
- 3/4" NPT rear gas manifold connection

AGENCY APPROVALS

- NSF Listed
- CSA Design Certified to ANSI Z83.11 • CSA 1.8



HDB-6 [Rev. 1/13]

LEGEND™ Heavy-Duty Gas Underfired Broilers — Ceramic Free-Standing Cabinet Base

Item No. _____

Project _____

Quantity _____

UFS-C Series

Dimensions in brackets are millimeters

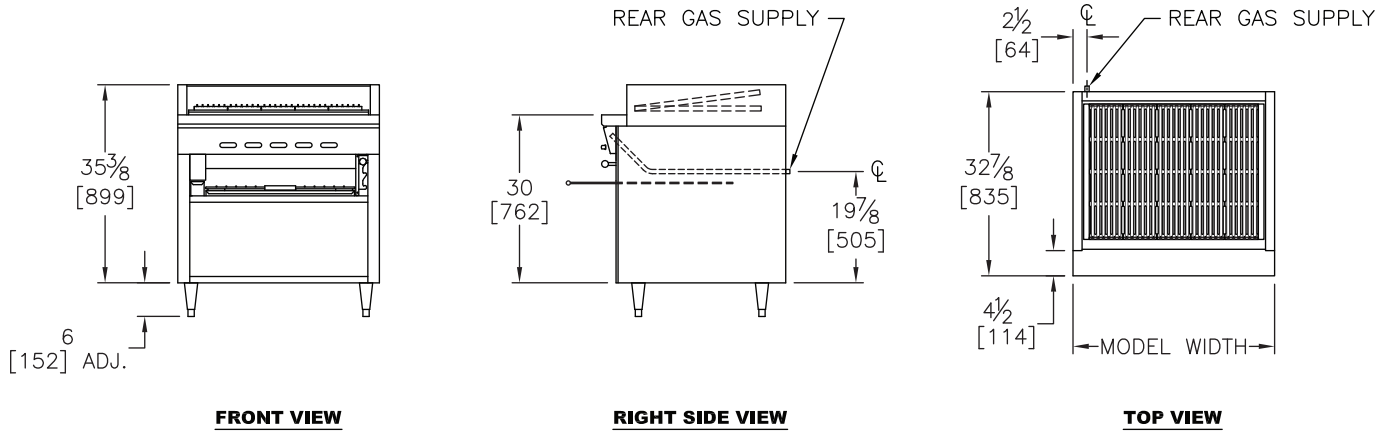

OPTIONS GUIDE:

General:

- Casters — set of four/six 5" (127mm) casters
- Flex Connector Kit [3/4"] or [1"] NPT:
 - 3' (914mm) long
 - 4' (1219mm) long
- Curb Mounting
- Lower Warming Rack
- Removable splash guard, stainless steel

Grates, Radiants,

Plate Shelves:

- Seafood grates, cast iron
- Round rod grates — 6" (152mm) sections:
 - Hard chrome
 - Cold rolled steel
- Scraper/cleaner for round rod grates

Finish/Cabinet Upgrades:

- Stainless steel left side panel
- Stainless steel right side panel
- Stainless steel back panel
- Add stainless steel cabinet bottom shelf
- Stainless steel cabinet base doors
- Stainless steel grease container

INSTALLATION REQUIREMENTS & SHIPPING INFORMATION

- Broilers must be installed in accordance with local codes or in their absence with the National Fuel Gas Code: ANSI Z223.1; Natural Fuel Gas Code: CAN/CGA-B149.1 or Propane Installation Code: CAN/CGA-B149.2, as applicable. Compliance with codes is the responsibility of the Owner and Installer.
- An adequate ventilation system is required. Refer to National Fire Protection Association Standard No. 96, "Standard for Ventilation and Fire Protection of Commercial Cooking Operations."
- This appliance is intended for commercial use by professionally trained personnel. NOT intended for Residential Use.
- Specify installation elevation: _____ if above 2000 feet (610m).
- GAS INLET SIZE (All Models): 3/4" NPT left rear inlet provided. A 3/4" NPT gas pressure regulator is provided and must be installed (by others) when unit is connected to gas supply.
- The incoming gas line pressure into the regulator should be 8"-14" w.c. for natural gas, and 12"-14" w.c. for propane gas.

Minimum Clearances	Noncombustible Construction
From Back Wall	0"
Left & Right Side	0"
For use in noncombustible locations only.	

Models:	Specify Type of Gas:	Manifold Pressure:		Shipping Weight	Shipping Class	Cube (Crated) ft ³ /m ³
		6.0" WC	10.0" WC			
Burners	BTU/hr (kW)	BTU/hr (kW)	BTU/hr (kW)			
UFS-24C	2	90,000 (26.4)	90,000 (26.4)	402 lbs (182 kg)	85	21/.6
UFS-30C	2	90,000 (26.3)	90,000 (26.3)	442 lbs (200 kg)	85	32/.9
UFS-36C	3	135,000 (39.6)	135,000 (39.6)	482 lbs (218 kg)	85	32/.9
UFS-48C	4	180,000 (52.7)	180,000 (52.7)	804 lbs (364 kg)	85	46/1.3
UFS-60C	4	180,000 (52.7)	180,000 (52.7)	884 lbs (400 kg)	85	65/1.8
UFS-72C	6	270,000 (79.1)	270,000 (79.1)	964 lbs (437 kg)	85	65/1.8



THE MONTAGUE COMPANY

1830 Stearman Avenue, Hayward, CA 94545

800 345-1830 • Fax: 510 785-3342

www.montaguecompany.com

Due to continuous product improvements, specifications are subject to change without notice.



HDB-6 [Rev. 1/13]