



Simply Engineered Better

Project _____
 Item No. _____
 Quantity _____

UNDERCOUNTER ACCESSORIES

Undercounter Accessories



P/N 0708757
17" Rack Stand

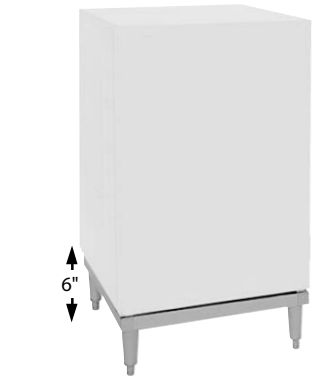

P/N 0712393
6" Stand



P/N 403561
CST Table System
 Machine on right

P/N 403562
CST Table System
 Machine on left (Pictured w/optional spray hose)*



P/N 180350
UDT-4R Table
 Machine on right

P/N 180374
UDT-4L Table
 Machine on left (Pictured w/optional spray hose)*

OPTIONS FOR TABLES

- Spray Hose with hot & cold mixing chamber (*pictured with both tables) P/N 100243
- 42" Overshelf – wall mounted stainless steel P/N 108189
- Garbage Disposal Unit – consult the factory P/N 110073
- Faucet
- 8" Back Splash

MD028 Printed in U.S.A.

Moyer Diebel – USA

P.O. Box 4183, Winston-Salem, NC 27115 Tel: 336/661-1992 Fax: 336/661-1979 800/228-8350 www.moyerdiebel.com

Moyer Diebel Ltd. – Canada

2674 North Service Rd., Jordan Station, Ontario, Canada L0R 1S0 Tel: 800/263-5798 Fax: 905/562-4618 sales@moyerdiebellimited.com



Dimensions shown in inches and [millimeters]

Details & Specifications

UDT Right Hand Sink

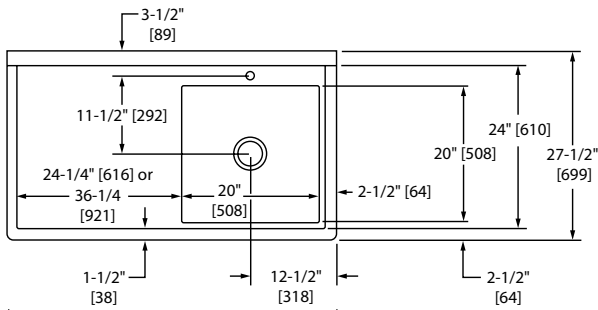

Plan View

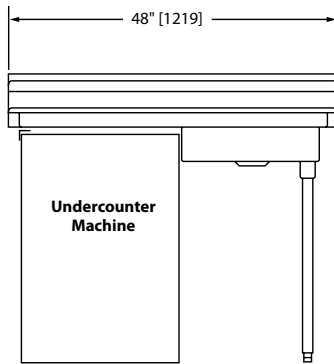

Front View

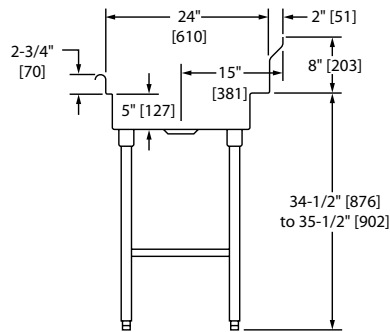

Side View

CST Right Hand Sink

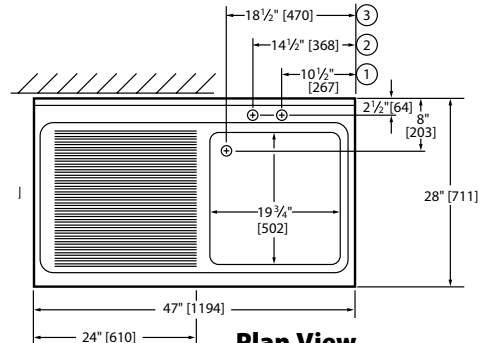

Plan View

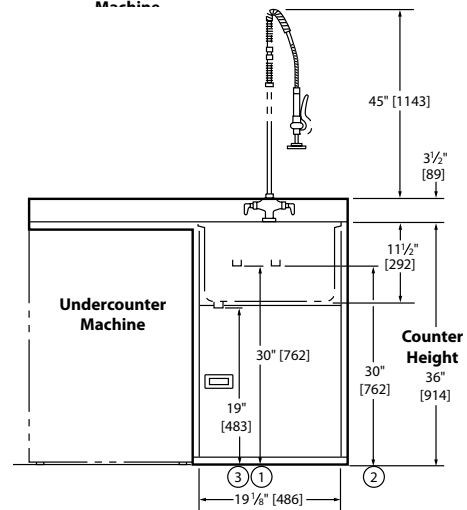

Front View

(Shown with optional spray hose)

Utilities	
1	1/2" NPT hot water
2	1/2" NPT cold water
3	1-1/2" drain [38mm] drain

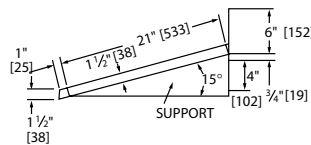

**Wall Mounted
Overshelf**

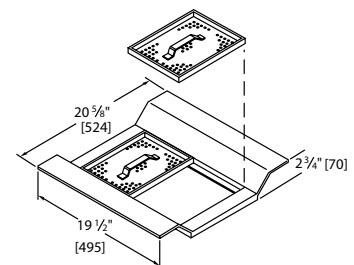

**Removable Scrap
Screen Holder**
(CST only)

SPECIFICATIONS

Approximate shipping weight

UDT: 100 lbs/45 kg.

CST: 167 lbs/76 kg.

Approximate shipping weight with shelf

UDT: 120 lbs/55 kg.

CST: 187 lbs/85 kg.

STANDARD FEATURES

- Constructed of heavy-gauge stainless steel.
- Specify right hand or left hand sink.