



**Pizza Prep Tables  
KPT SERIES**

Project name:	
Location:	
Item:	Qty:
Model:	

KPT SERIES

**44"**  
KPT-44-1

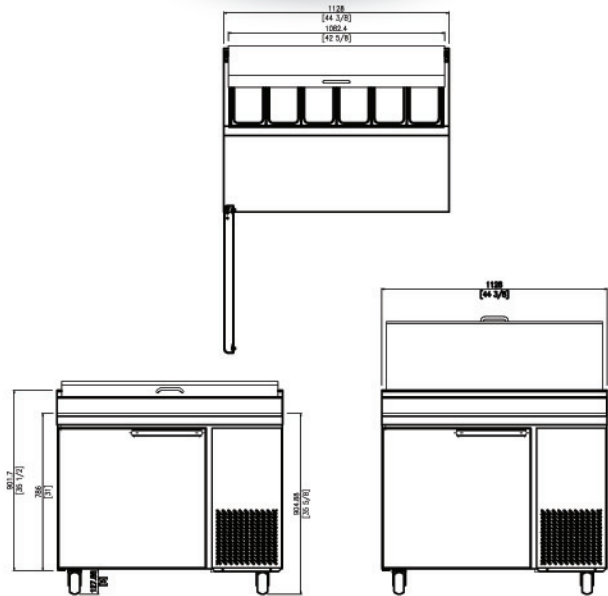

Dimensions (W" x D" x H")  
44.4 x 36.6 x 42.0

**67"**  
KPT-67-2

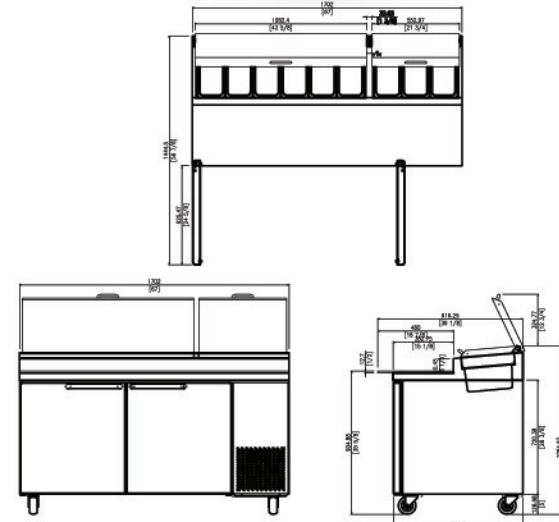

Dimensions (W" x D" x H")  
67.0 x 36.6 x 42.0

**93"**  
KPT-93-3

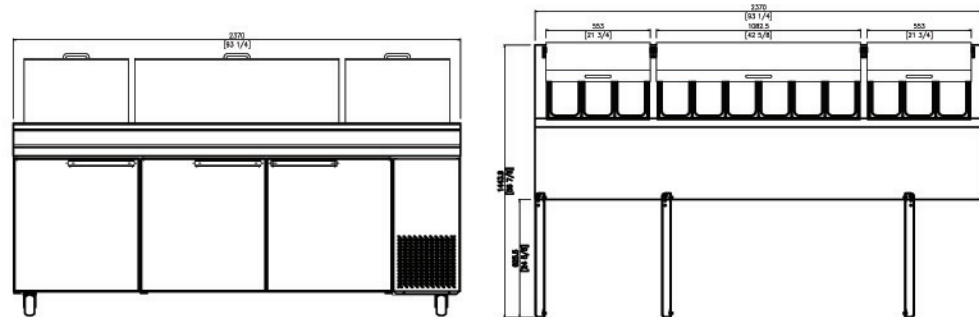

Dimensions (W" x D" x H")  
93.3 x 36.6 x 42.0



**44"**  
KPT-44-1



**67"**  
KPT-67-2



**93"**  
KPT-93-3

KOOL-IT is a registered trade mark of MVP Group.  
Specifications subject to change without notice.



Tel.: 514.737.9701 / Toll Free: 888.275.4538  
Fax: 514.342.3854 / Toll Free: 877.453.8832  
sales@mvpgroupcorp.com www.mvpgroupcorp.com



Tel.: 514.737.9701 / Toll Free: 888.275.4538  
Fax: 514.342.3854 / Toll Free: 877.453.8832  
sales@mvpgroupcorp.com www.mvpgroupcorp.com

## Pizza Prep Tables

Model Number	Capacity (cubic feet)	Number of Doors	Number of Shelves	Number of Pans	Refrigerant	HP	Amps	Ship Weight (lbs.)	Ship Dimensions W" x D" x H"
KPT-44-1	11.3	1	2	6	R-134-a	3/8	6.5	410	44.4x36.6x42
KPT-67-2	20.2	2	4	9	R-134-a	3/8	6.5	550	67.0x36.6x42
KPT-93-3	30.8	3	6	12	R-404-a	1/2	7.5	690	93.3x36.6x42

Voltage : 115/60/1

NEMA 5-15 plug

These units are designed for maximum performance in an air-conditioned area of 75°F ambient temperature and 55% relative humidity. There must be adequate ventilation at the top, sides & rear of the unit for proper operation.

Warranty : 18 months parts & labor. Additional 42 months on compressor (part only)



## Energy Efficient

- Self-closing door with stay-open feature
- Seal tight with magnetic vinyl gasket
- Foamed-in place high-density polyurethane insulated body, CFC-Free
- 1" thick insulated lids

## Durable Design

- Created to endure the everyday stress of the commercial kitchen environment, to protect your long term investment and guarantee superior food preservation
- 2 height adjustable, heavy-duty, PE coated wire shelves per door
- Spring loaded, self-closing doors
- Removable, easy to clean cutting board
- Simple plug-in installation

## Superior Quality

- Designed for mobility, reliability & efficiency in commercial kitchens
- 5" swivel castors with 2 front brakes
- 36" high working surface
- Easy grip door handle(s)
- Entirely self-contained system
- Forced air refrigeration
- Automatic defrost system
- Easily adjustable shelf height
- Stainless Steel interior & exterior
- Polycarbonate food pans included

KPT Series Pizza Prep Tables

- Temperature range : 32°F to 45°F