



Project name:	
Location:	
Item:	Qty:
Model:	

Sandwich Prep Tables
KST SERIES



27"
KST-27-1



36"
KST-36-2



48"
KST-48-2



60"
KST-60-2



72"
KST-72-3

27"
KST-27-1

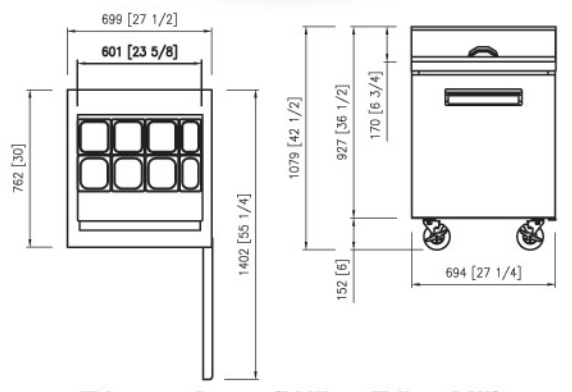

Dimensions (W" x D" x H")
27.5 x 30 x 42.5

36"
KST-36-2

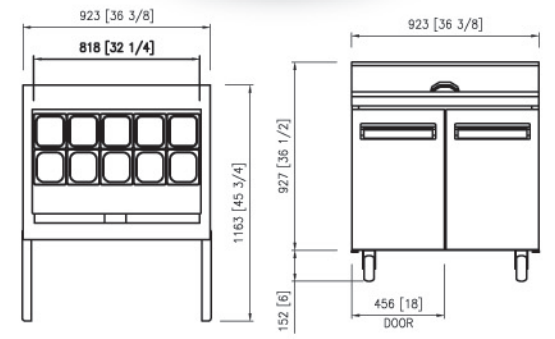

Dimensions (W" x D" x H")
36.4 x 30 x 42.5

48"
KST-48-2

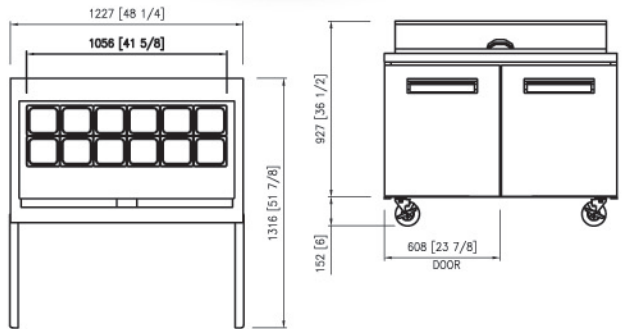

Dimensions (W" x D" x H")
48.3 x 30 x 42.5

60"
KST-60-2

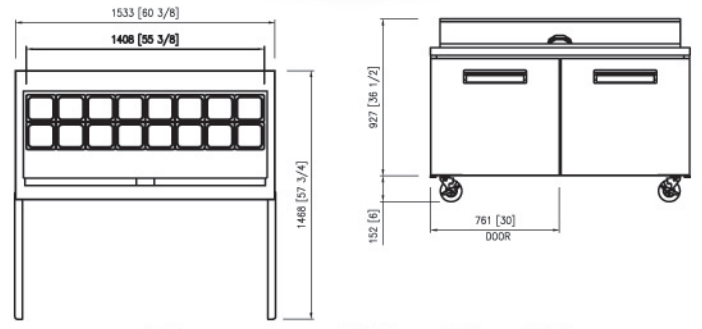

Dimensions (W" x D" x H")
60.4 x 30 x 42.5

72"
KST-72-3

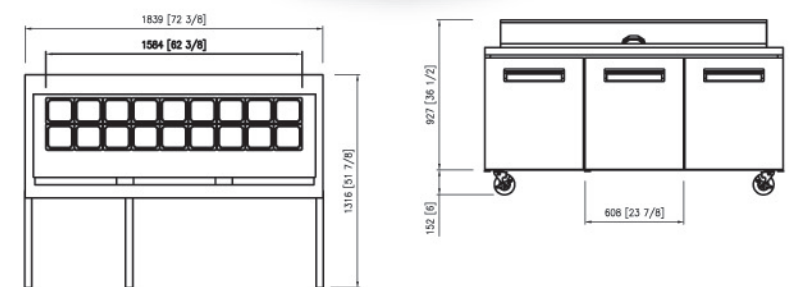

Dimensions (W" x D" x H")
72.4 x 30 x 42.5

KOOL-IT is a registered trade mark of MVP Group.
Specifications subject to change without notice.



Tel.: 514.737.9701 / Toll Free: 888.275.4538
Fax: 514.342.3854 / Toll Free: 877.453.8832
sales@mvpgroupcorp.com www.mvpgroupcorp.com



Tel.: 514.737.9701 / Toll Free: 888.275.4538
Fax: 514.342.3854 / Toll Free: 877.453.8832
sales@mvpgroupcorp.com www.mvpgroupcorp.com

KST SERIES

Sandwich prep tables

Model Number	Capacity (cubic feet)	Number of Doors	Number of Shelves	Number of Pans	HP	Amps	Ship Weight (lbs.)	Ship Dimensions W" x D" x H"
KST-27-1	6.8	1	1	8	1/5	3.4	212	27.5x30x42.5
KST-36-2	9.2	2	2	10	1/5	3.4	256	36.4x30x42.5
KST-48-2	12.7	2	2	12	3/8	6.0	304	48.3x30x42.5
KST-60-2	16	2	2	16	3/8	6.0	344	60.4x30x42.5
KST-72-3	19.6	3	3	18	3/8	6.1	384	72.4x30x42.5

Voltage : 115/60/1

NEMA 5-15 plug

These units are designed for maximum performance in an air-conditioned area of 75°F ambient temperature and 55% relative humidity. There must be adequate ventilation at the top, sides & rear of the unit for proper operation.

Warranty : 18 months parts & labor. Additional 42 months on compressor (part only)



Energy Efficient

- Self-closing door with stay open feature
- Seals tight with magnetic vinyl gasket
- Foamed-in place high-density polyurethane insulated body, CFC-Free
- Environmentally friendly R-134a refrigerant
- 1" thick insulated lids

Durable Design

- Created to endure the everyday stress of the commercial kitchen environment, to protect your long term investment and guarantee superior food preservation
- 1 height adjustable, heavy-duty, PE coated wire shelf per door
- Spring loaded, self closing doors
- Removable, easy to clean cutting board
- Simple plug-in installation

Superior Quality

- Designed for mobility, reliability & efficiency in commercial kitchens
- 5" swivel castors with 2 front brakes
- 36" high working surface
- Easy grip handle(s)
- Entirely self-contained system
- Forced air refrigeration
- Automatic defrost system
- Easily adjustable shelf height
- Stainless Steel interior & exterior
- Polycarbonate food pans included

KST Series Sandwich Prep Tables

- Temperature range : 32°F to 45°F