



PROJECT NAME: _____

LOCATION: _____

ITEM: _____ QTY: _____

MODEL: _____

SRF-75/80

TUBE FIRED GAS FRYER

The Sierra all-purpose fryers feature outstanding reliability and durability, capable of cooking a wide variety of fried foods with consistent uniformity and great taste.

Three highly efficient cast iron burners and stainless steel tubes create a large heat transfer area for even heat distribution. Our durable temperature probe senses temperature changes and activates a quick burner response. The temperature for the SRF-75/80 ranges from 200°F (93°C) to 400°F (204°C). Includes Millivolt safety control system.

Every inch of the frypot and cold zone can be cleaned and wiped down by hand. The large cold zone and forward sloping bottom help collect and remove sediment from the frypot to safeguard oil quality and support routine frypot cleaning.

6" swivel casters are optional (2 locking, 2 non-locking).



TUBE FIRED

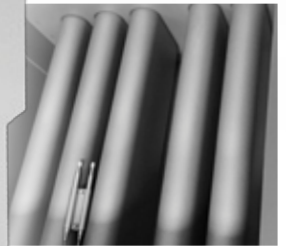

Fully peened tank ensures easy cleaning

STANDARD FEATURES

- 🔥 150,000 BTUs/hr.
- 🔥 Large cold zone area.
- 🔥 Delivers heat through 6" x 2" 16-gauge stainless steel heat exchange tubes for even heat transfer and rapid temperature recovery
- 🔥 Frypot is manufactured from 439 grade stainless steel.
- 🔥 1.25" stainless steel full port ball type drain valve.
- 🔥 Stainless steel door is reinforced for added strength with a heavy duty magnetic door catch.
- 🔥 Stainless steel front. Galvanized side and back panels.
- 🔥 Twin fry baskets with plastic coated handles. Stainless steel basket hanger, easily removable for cleaning.
- 🔥 Robertshaw snap action millivolt thermostat control adjusts from 200°F-400°F. No electrical hook-up required.
- 🔥 Hi-limit shut-off protector shuts off gas combination valve and standing pilot.
- 🔥 Built-in flue deflector.
- 🔥 Nickel-plated tube rack.
- 🔥 Set of four stainless steel adjustable legs.
- 🔥 The SRF-75/80 is available for Natural Gas or Liquid Propane installation. Please specify gas when ordering.



Tel.: 786.600.4687 / Toll Free: 844.218.8477
Fax: 786.661.4100



Tel.: 514.737.9701 / Toll Free: 888.275.4538
Fax: 514.342.3854 / Toll Free: 877.453.8832
sales@mvpgroupcorp.com

MVP
GROUP

www.mvpgroupcorp.com

When placing an order, please specify your preferred configuration; for LP (SRF-75/80 LP) or for Natural Gas (SRF-75/80 NG)

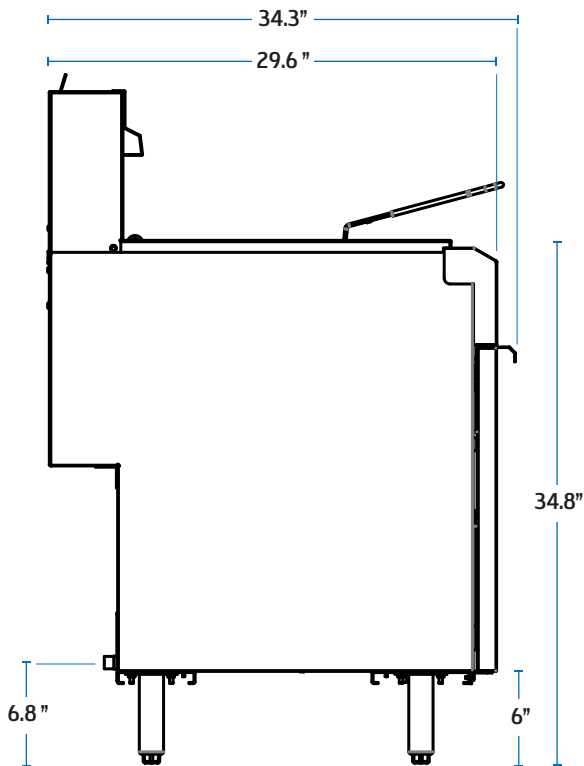
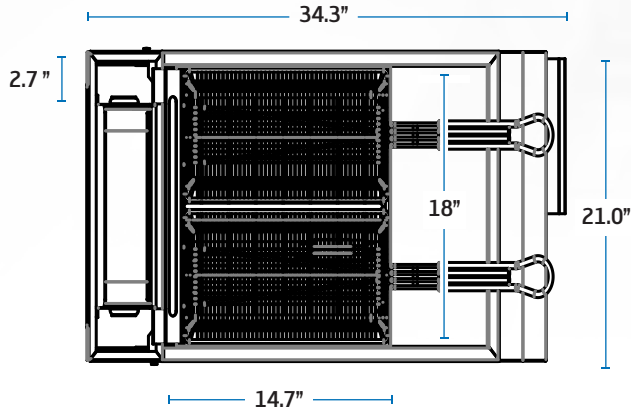

SPECIFICATIONS

MODEL NUMBER	SRF-75/80 (NG OR LP)
EXTERNAL DIMENSIONS (WxDxH) INCLUDING HANDLE	21" X 34.3" X 53.2"
NUMBER OF BURNERS	5
FRYER CAPACITY	75-80 LBS
BTU (EACH BURNER AT 5" W.C.)	30,000
TOTAL BTU	150,000
NET WEIGHT	210 LBS
SHIPPING WEIGHT	265 LBS

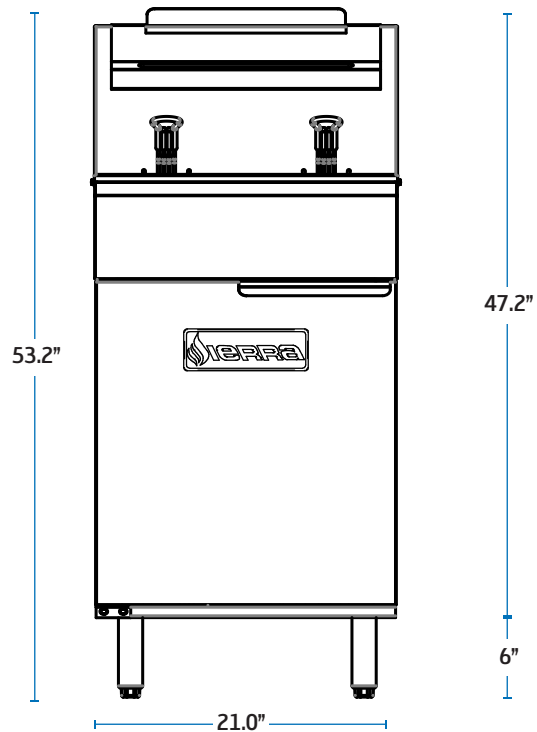

Warranty: 12 months parts & labor. Additional fry tank warranty to the original purchaser only: If the fry tank has leaked because of a manufacturing defect, as confirmed by an MVP Group servicer within the first two years of operation, MVP Group shall replace the fryer. Refer to Operators Manual for full details. Freight or installation charges shall not be included.

Gas Connection: 3/4" NPT on the right-hand rear of the appliance. The pressure regulator (supplied) is to be connected here by the installer.
Gas pressure: 4" W.C. - Natural Gas | 10" W.C. - Propane

Clearances: Combustible: 6 inches sides, 6 inches rear, 16 inches to adjacent open flame burner units | **Non-combustible:** 0 inches sides, 0 inches rear, 16 inches to adjacent open burner flame units. Specify type of gas and altitude, if over 2,000 feet, when ordering.

SIERRA RANGE is a registered trademark of **MVP Group**.

Due to continuing product development, to ensure best possible performance, the specifications are subject to change without prior notice.