

JOB:  
ITEM:  
QTY:

# SLANT DISPLAY RACK

## APPLICATION:

This rack is designed to provide an attractive display with high product visibility.

## MATERIAL:

Frame is constructed of 1"x1"x.070" wall tubing. Angle runners are 1 1/4"x1 5/8"x.100" wall. Tube is reinforced with a channel to help prevent breakage from the stem casters.

## CASTERS:

These racks come equipped with four 5" stem type swivel casters.

## GUARANTEE:

These racks carry a **Lifetime Guarantee** against rust and corrosion and also carry a **Five-Year Guarantee** against workmanship and material defects.



Model #1137



Phone:800-255-0104  
Fax: 877-877-7687  
[www.newageindustrial.com](http://www.newageindustrial.com)  
[sales@newageindustrial.com](mailto:sales@newageindustrial.com)

New Age Industrial reserves the right to modify or make changes at any time without notice to materials and specifications.

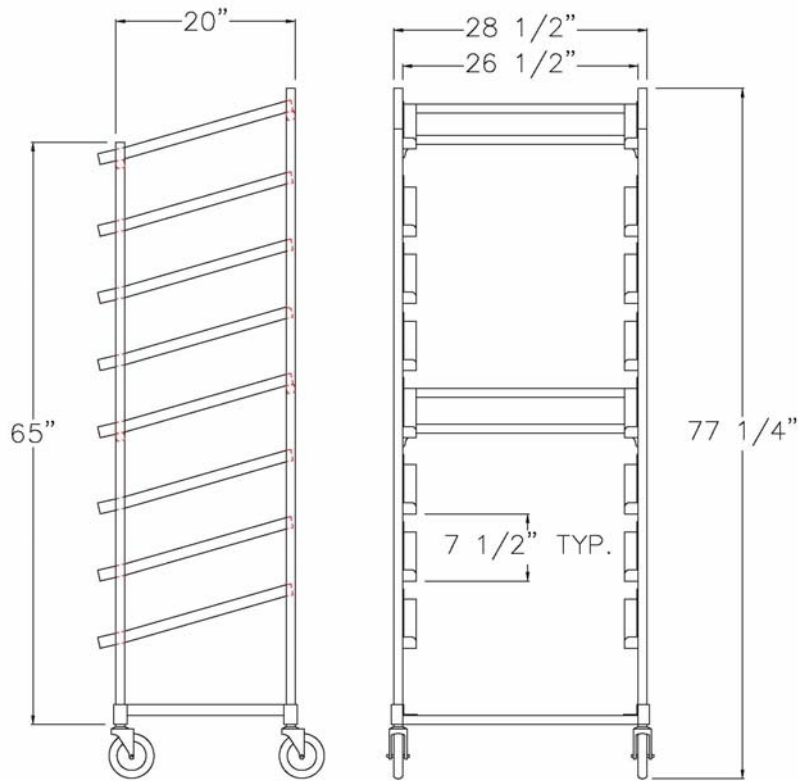

**Model #1139**

Model No.	Size-W	Size-H	Size-D	Runner Spac.	Pan Cap.
1137	28 1/2"	70"	22"	8 3/4"	7
1139	28 1/2"	77 1/4"	22"	7 1/2"	9



Phone: 800-255-0104  
 Fax: 877-877-7687  
[www.newageindustrial.com](http://www.newageindustrial.com)  
[sales@newageindustrial.com](mailto:sales@newageindustrial.com)

New Age Industrial reserves the right to modify or make changes at any time without notice to materials and specifications.