

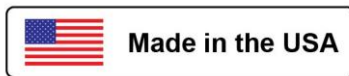

JOB:
ITEM:
QTY:



LUG DOLLIES- RAC LINE

APPLICATION:

These lug dollies are ideal for bulk food transporting. They accept the standard lugs (16"Wx8 1/2"Hx25"L).

MATERIAL:

Framework is constructed out of 1 1/4"x 1 1/4"x.070" wall tubing. Angle runners are 1 1/4"x1 1/4"x.100" wall angle.

CASTERS:

These dollies come equipped with four 5" stem type swivel casters.

GUARANTEE:

These dollies carry a **Lifetime Guarantee** against rust and corrosion and also carry a **One-Year Guarantee** against workmanship and material defects.



Model #6262



Phone:800-255-0104
Fax: 877-877-7687
www.newageindustrial.com
sales@newageindustrial.com

New Age Industrial reserves the right to modify or make changes at any time without notice to materials and specifications.

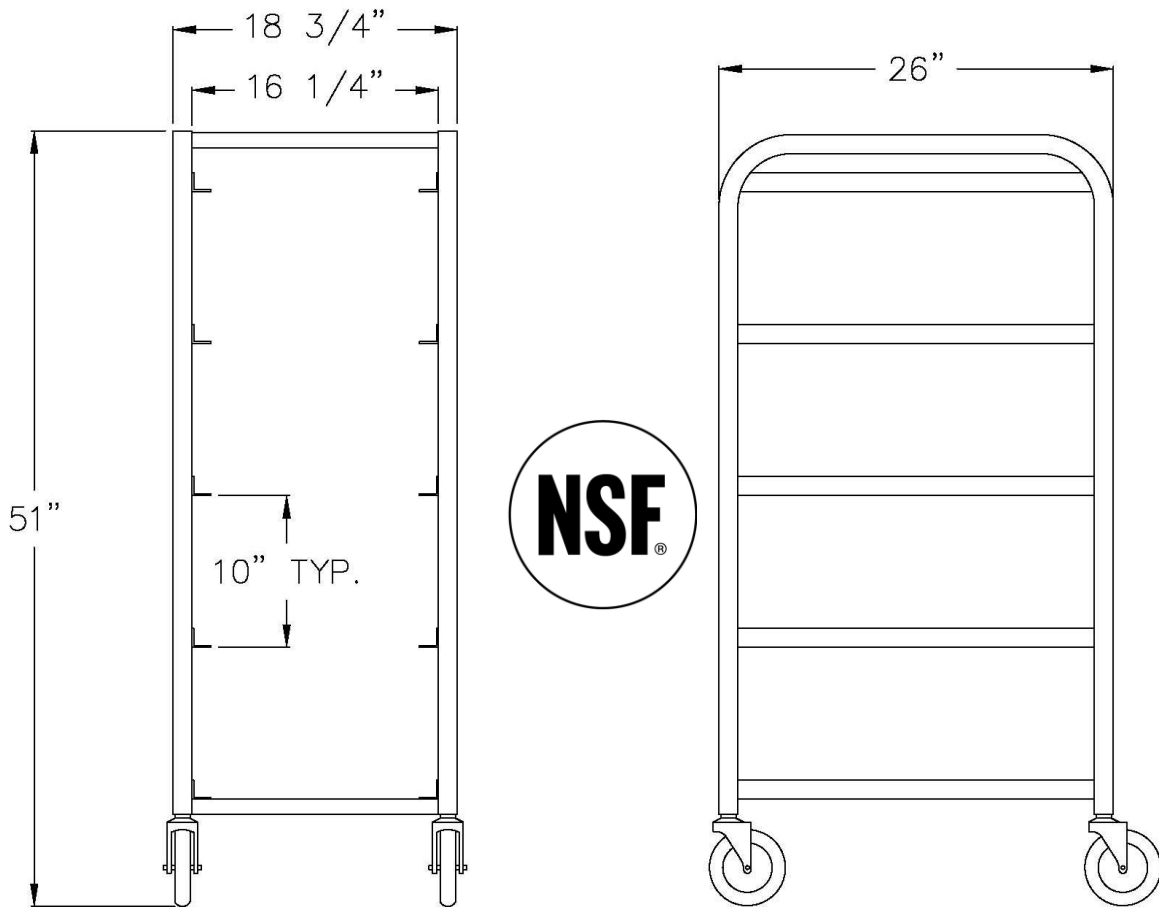

Model #6262

Model No.	Size-W	Size-H	Size-D	Lug Cap.
6265	15 3/4"	19"	26"	1
6266	15 3/4"	33"	28 1/4"	2
97205	18 3/4"	42"	26"	3
6262	18 3/4"	51"	26"	4
97253	18 3/4"	61"	26"	5
6263	19 1/2"	70"	26"	6



Phone: 800-255-0104
 Fax: 877-877-7687
www.newageindustrial.com
sales@newageindustrial.com

New Age Industrial reserves the right to modify or make changes at any time without notice to materials and specifications.