



JOB:
ITEM:
QTY:

96005C-MEAL DEAL CART

Application:

A more economical design than a fully enclosed delivery cart. Transports 15" x 20" trays with ease with our platform caster design.

Material:

Base is constructed of 1 1/2" x 1 1/2" x .070" wall tubing, upper frame is constructed of 1 1/4" x 1 1/4" x .070" wall tubing, angle runners are 1 1/4" x 1 5/8" x .070" wall angle, and base is covered with .063" aluminum sheet. The top has a removable tray that is constructed out of .063" sheet.

Casters:

This cart is equipped with four 6" platform type casters. Two are swivel and two are rigid. Non-marking wheels protect floors and minimize noise.

Guaranteed to Last:

Guaranteed to last, this cart carries a **Lifetime Guarantee** against rust and corrosion as well as a **Five-Year Guarantee** against material defects and workmanship.



Model #96005C



Phone: 800-255-0104
Fax: 877-877-7687
www.newageindustrial.com
sales@newageindustrial.com

New Age Industrial reserves the right to modify or make changes at any time without notice to materials and specifications.

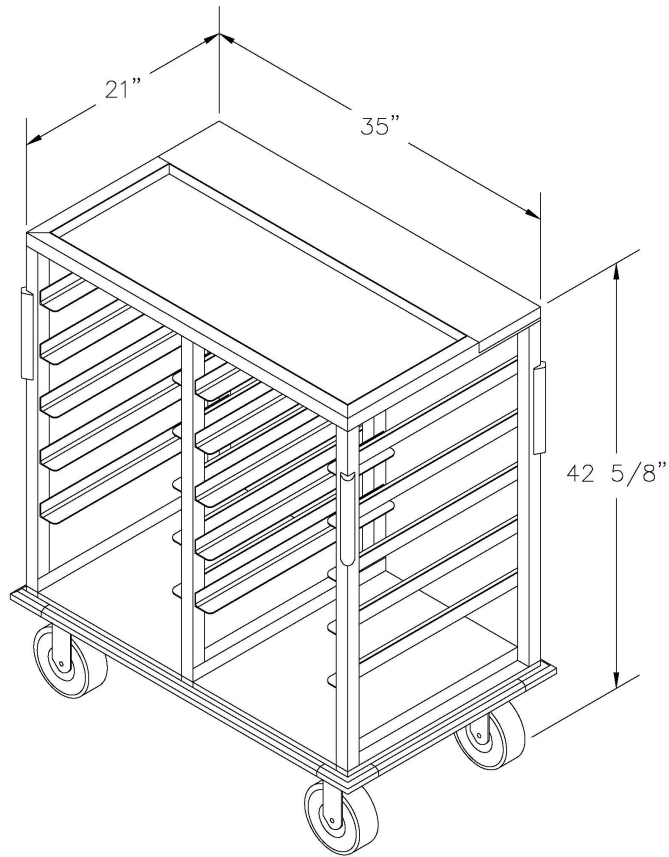

Model #96005C

Model No.	Size-W	Size-H	Size-D	Runner Spacing	Pan Cap.
96005C	36 3/4"	42 3/4"	23"	5"	12



Phone: 800-255-0104
 Fax: 877-877-7687
www.newageindustrial.com
sales@newageindustrial.com

New Age Industrial reserves the right to modify or make changes at any time without notice to materials and specifications.