



JOB:  
ITEM:  
QTY:



## FOLDING UTILITY CART

### APPLICATION:

This cart is ideal for transporting heavy loads from the back room to the floor area or cooler. With this cart it is big enough that you can stock a complete area with one trip. When complete this cart stores upright to maximize the available storage space.

### MATERIAL:

Framework is constructed out of 1 1/2x 1 1/2"x.070" wall tubing. Handle is constructed out of 1 1/2" diameter pipe and is reinforced by 1/2"x1"x.070" wall tubing.

### CASTERS:

This cart comes equipped with four 5" platform type swivel casters and two 6"x2" platform type rigid casters.

### GUARANTEE:

This cart carries a **Lifetime Guarantee** against rust and corrosion and also carries a **Five-Year Guarantee** against workmanship and material defects.



**Model #96856**



Phone: 800-255-0104  
Fax: 877-877-7687  
[www.newageindustrial.com](http://www.newageindustrial.com)  
[sales@newageindustrial.com](mailto:sales@newageindustrial.com)

New Age Industrial reserves the right to modify or make changes at any time without notice to materials and specifications.

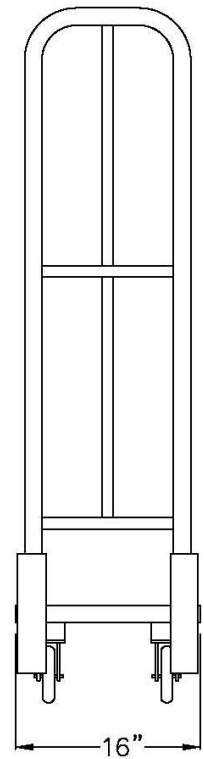
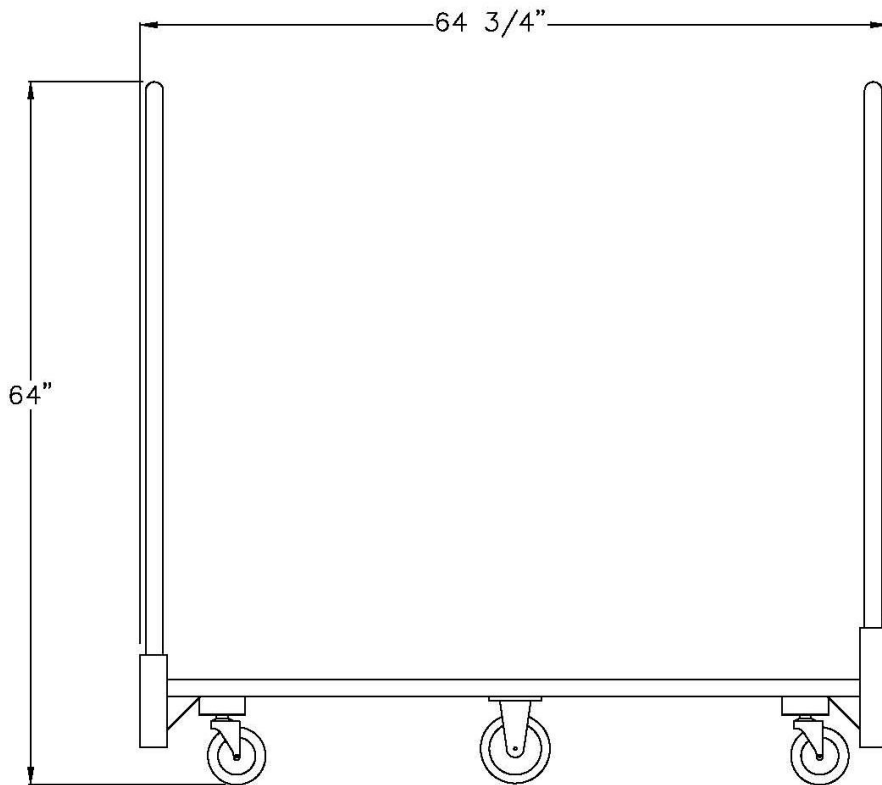

**Model #96856**

Model No.	Size-W	Size-H	Size-D	Size Folded	Wt. Cap.
96856	16"	64"	64 3/4"	16"x14"x64 3/4"	1500#

Options: "TP"-Tread plate deck cover.

"E"-Solid base, .063" smooth sheet.



Phone: 800-255-0104  
 Fax: 877-877-7687  
[www.newageindustrial.com](http://www.newageindustrial.com)  
[sales@newageindustrial.com](mailto:sales@newageindustrial.com)

New Age Industrial reserves the right to modify or make changes at any time without notice to materials and specifications.