



JOB:
ITEM:
QTY:



WET PRODUCE CART-RAC LINE

APPLICATION:

This double deck cart moves product at a convenient, workable height from the floor. Removable drip pan helps keep things dry and clean.

MATERIAL:

Framework is constructed out of 1 1/4"x1 1/4"x .070" wall tubing. Removable drip tray is constructed out of .080" aluminum sheet. Handle is constructed out of 1"x1"x.070" wall tubing.

CASTERS:

This cart comes equipped with four 5" platform type casters, two swivel and two rigid.

GUARANTEE:

This rack carries a **Lifetime Guarantee** against rust and corrosion and also carries a **One-Year Guarantee** against workmanship and material defects.



Model #97126



Phone: 800-255-0104
Fax: 877-877-7687
www.newageindustrial.com
sales@newageindustrial.com

New Age Industrial reserves the right to modify or make changes at any time without notice to materials and specifications.

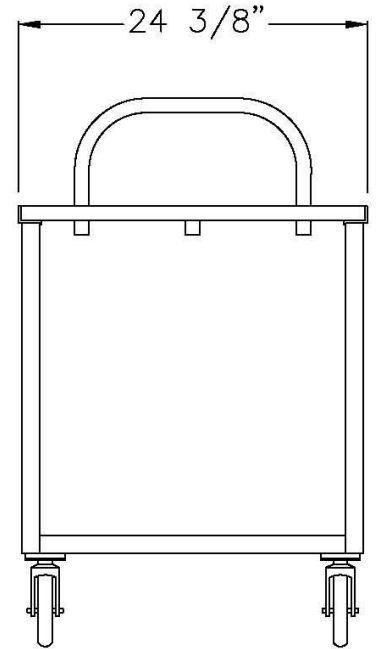
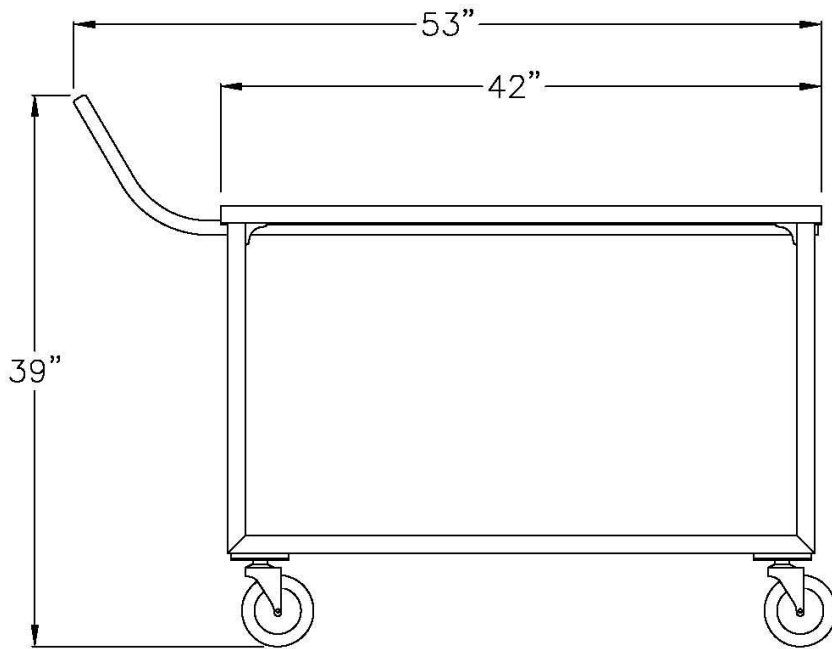

Model #97126

Model No.	Size-W	Size-H	Size-D	Wt. Cap.	No. Casters
Carts W/One (1) Removable Pans					
97126	24 3/8"	39"	53"	700#	4



Phone: 800-255-0104
 Fax: 877-877-7687
www.newageindustrial.com
sales@newageindustrial.com

New Age Industrial reserves the right to modify or make changes at any time without notice to materials and specifications.