

NOR-LAKE, INCORPORATED
727 Second Street
P.O. Box 248
Hudson, Wisconsin 54016

800-955-5253
715-386-2323
800-388-5253 Service
866-961-5253 Parts
715-386-6149 FAX
www.norlake.com

NORLAKE®



ICE CRUSHER



PROJECT:

ITEM NUMBER:

MODEL NUMBER:

ICE CRUSHER

SPECIFICATIONS FOR: N14CR

- **Exterior finish:** Exterior front, back and sides are stainless steel. Top and access door are stainless steel.
- **Interior finish:** Ice hopper is stainless steel.
- **Capacity:** Crushes large ice cubes into smaller chips. For use on salad bars or for iced drinks.
- **Hardware:** Select type of ice in coarse, medium or fine, by means of front lever. Ice is deposited in a large capacity poly carbonate tote pan. Unit is equipped with a safety guard to protect the operator.
- **Electrical:** Protected power switch to prevent accidental start of motor. Motor protected by remote circuit breaker located near power switch.
- **Approvals:** UL, C-UL and UL Sanitation listed.

STANDARD FEATURES

- Poly carbonate tote pan
- Stainless steel exterior
- Stainless steel top and access door
- Stocked for same day shipment
- UL listed and UL Sanitation listed
- Warranties: 1 year parts and labor

OPTIONAL FEATURES*

- Extra poly carbonate tote pan



Nor-Lake, Inc.
Registered to ISO 9001:2008
File No. 10001816

* Most options are available two weeks from receipt of order. Please contact us for specific questions.

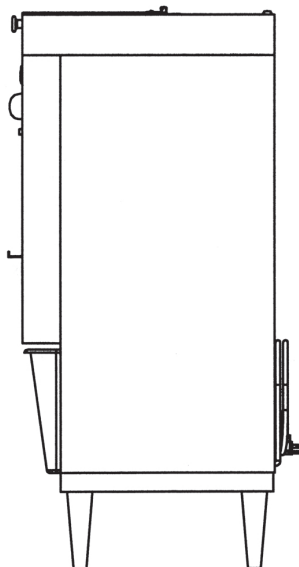
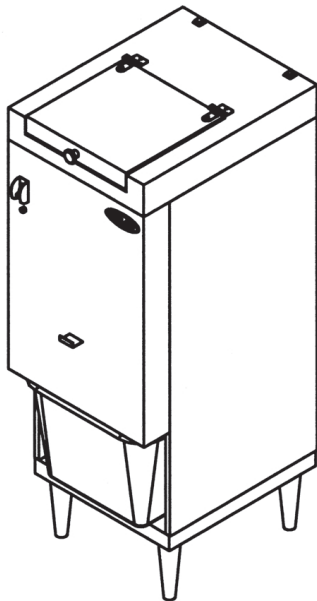
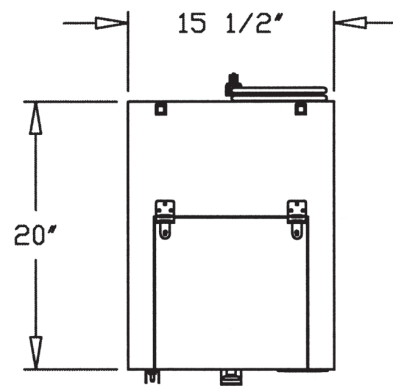
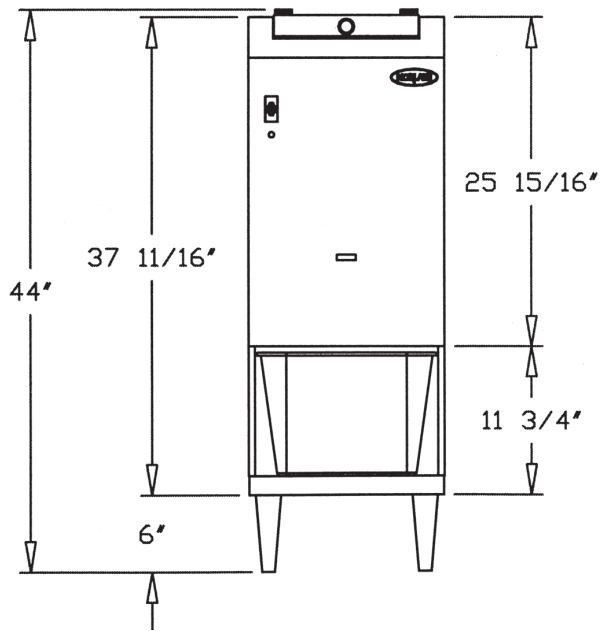

SPECIFICATIONS

N14CRSS-A

<i>Crated Height</i>	41"
<i>Crated Width</i>	23-1/4"
<i>Crated Depth</i>	19-5/8"
<i>Crated Weight (lbs.)</i>	120
<i>Overall Height</i>	44"
<i>Overall Width</i>	15-1/2"
<i>Overall Depth</i>	20"
<i>Tote Pan Capacity</i>	4.75 gal.
<i>Motor Size</i>	1/4 HP
<i>Electrical Characteristics</i>	115/60/1
<i>Cord and Plug Furnished</i>	Yes
<i>NEMA Plug Configuration</i>	5-15P
<i>Maximum Fuse Size</i>	15
<i>Total Amp Draw</i>	6.4

Specifications subject to change without notice.



Revision Date: 10/09
 © 2009 NOR-LAKE, INC.
 Printed in the U.S.A.
 Part Number: 089714

