

UNDERCOUNTER/COUNTERTOP BLAST CHILLERS



NBC40-4

PROJECT:
.....
ITEM NUMBER:
.....
MODEL NUMBER:
.....

UNDERCOUNTER/COUNTERTOP BLAST CHILLERS

SPECIFICATIONS FOR: NBC40-4

- **Exterior finish:** Stainless steel exterior; satin scotchbrite finish on door, side panels, control panel and top.
- **Interior finish:** Stainless steel, polished interior including diamond polished inner floor for improved hygiene.
- **Insulation:** The complete cabinet and door(s) are foamed-in-place with CFC-free polyurethane insulation.
- **Hardware:** One-piece construction with rounded internal corners; removable stainless steel half racks and container support guides; plastic defrost drip tray on outer base; stainless steel legs with plastic heat resistant pads; height adjustable from 4.0" to 5.3"; standard multi-point product probe with L-shaped handle for easy extraction; self closing door with full-height outer stainless steel handle; removable magnetic gasket; door frame heating element.
- **Electrical:** 220/60/1
- **Instrumentation:** Microprocessor based controller with LCD display - 2 rows x 16 characters; blast chilling with variable cycle progression; 20 pre-set blast-chilling cycles; displays interior temperature, product temperature and ventilation speed; maintains temperature at end of blast chilling cycle.
- **Refrigeration:** R-404A refrigerant; Evaporator temperature control done with thermostatic valve and variable speed evaporator fans; Hinged evaporator coil cover for easy cleaning of evaporator coil; Drain outlet for easy interior cleaning; Copper/Aluminum corrosion-proofed evaporator coil; electronically controlled, manual defrost. The chilling process will take product from 160°F to 38°F in 90 minutes.
- **Approvals:** UL and NSF approved

STANDARD FEATURES

- Adjustable legs with plastic heat resistant pads
- Door frame heater
- CFC-free polyurethane insulation
- Hermetic compressor
- Copper/aluminum corrosion resistant evaporator
- LCD digital display
- L-shaped handle
- Manual Defrost
- R-404A refrigerant
- Removable magnetic door gasket
- Stainless steel half racks
- Stainless steel, polished interior
- Stainless steel exterior
- UL electrical and sanitation
- Warranties: 12 month parts and labor



Nor-Lake, Inc.
Registered to ISO 9001:2008
File No. 10001816

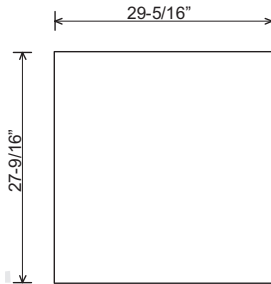

NBC40-4 - Top View

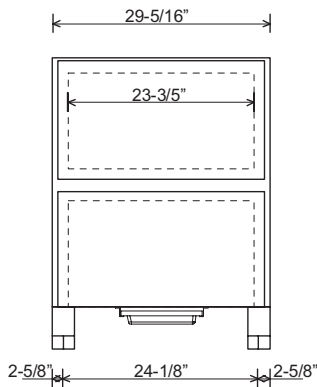

NBC40-4 - Front Views

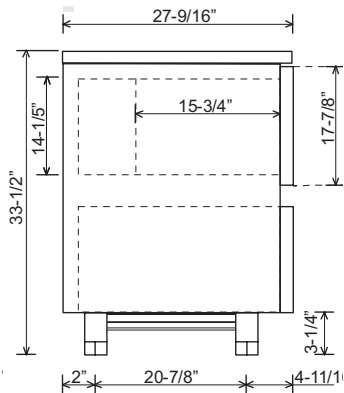

NBC40-4 - Side Views

SPECIFICATIONS

Models	NBC40-4
Crated Height (in)	41-1/3"
Crated Width (in)	31-9/10"
Crated Depth (in)	30-1/3"
Crated Weight (lbs)	276
Interior Height (in)	14-1/5"
Interior Width (in)	23-3/5"
Interior Depth (in)	15-3/4"
Overall Height (in)	33-1/2"
Overall Width (in)	29-5/16"
Overall Depth (in)	27-9/16"
Shelf Area (sq. ft.)	15-3/4" x 23-11/16"
Number of Shelves	2
Number of Legs	4
Condensing Unit Size	1/2 HP
Refrigerant	R-404A
Electrical Characteristics	220/60/1
Cord & Plug Furnished	No
Maximum Fuse Size	15 AMPS
Total Amp Draw	4

Specifications subject to change without notice.



Revision Date: 11/10
 ©2010 NOR-LAKE, INC.
 Printed in the U.S.A.
 Part Number: 143365

