

NOR-LAKE, INCORPORATED
 727 Second Street
 P.O. Box 248
 Hudson, Wisconsin 54016

800-955-5253
 715-386-2323
 866-961-5253 Parts
 800-388-5253 Service
 715-386-4291 FAX
 www.norlake.com



NXBF SERIES ICE CREAM HARDENING & HOLDING CABINETS



NXBF48

PROJECT:

ITEM NUMBER:

MODEL NUMBER:

SPECIFICATIONS FOR: NXBF27 & NXBF48

- **Exterior Finish:** Exterior front is stainless steel. Sides are anodized aluminum
- **Interior Finish:** Interior is anodized aluminum
- **Insulation:** The complete cabinet and door(s) are foamed-in-place with polyurethane insulation
- **Hardware:** Heavy duty, pivot hinges; Horizontal door handles; sure sealing magnetic gaskets (replaceable); casters and 4 epoxy coated cantilever shelves per door - standard; anti-condensate door frame heater. Lift off inner and outer doors.
- **Electrical:** Standard electronic control; allows user to easily monitor defrost functions from the panel interface on the front of the merchandiser; audible and visual alarm; decreases service time and calls, eliminates room thermostat, defrost termination/ fan delay control, defrost timer and digital thermometer or other temperature indicator.
- **Instrumentation:** Digital thermometer
- **Refrigeration:** Refrigerant: R-404A; self-contained, top mounted, semi-hermetic refrigeration system; minimum 4" clearance required between cabinet back and wall; R-factor (insulation efficiency rating): 21.55 on walls, 17.24 on doors; Temperature range: 0° to -37° F
- **Approvals:** UL Listed**
C-UL listed**
NSF Listed

STANDARD FEATURES

- Anodized aluminum interior
- Anti-condensate door frame heater
- Automatic defrost
- Electric condensate evaporation
- Epoxy coated shelves
- Horizontal work flow handle
- Lift-off inner and outer doors
- Magnetic gasketing
- Operating temperature: 0° to -37° F
- Polyurethane insulation
- Self-closing doors with 90° hold-open feature
- Stainless steel exterior
- Standard electronic control
- 2" stainless steel foamed-in-place doors
- UL, C-UL, & NSF listed
- Warranties: 5 year compressor & 1 year parts and labor

OPTIONAL FEATURES*

- Casters
- Extra epoxy-coated cantilever shelves
- Pan rack
- Voltage boosting transformer
- Add suffix "R" for remote system on NXBF48 only



Nor-Lake, Inc.
 Registered to ISO 9001:2008
 File No. 10001816

*Most options are available one week from receipt of order. Please contact us for specific questions.

**C-UL is Underwriters Laboratories Safety Certification Mark which indicates that UL has tested the equipment to applicable CSA Standards.

**UL Sanitation is Underwriters Laboratories Sanitation Mark which indicates that UL has tested the equipment to applicable NSF Standards.

HARDENING & HOLDING CABINETS

SPECIFICATION
GUIDE

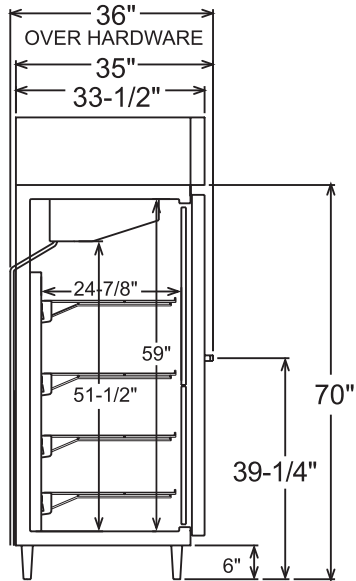

SIDE VIEW

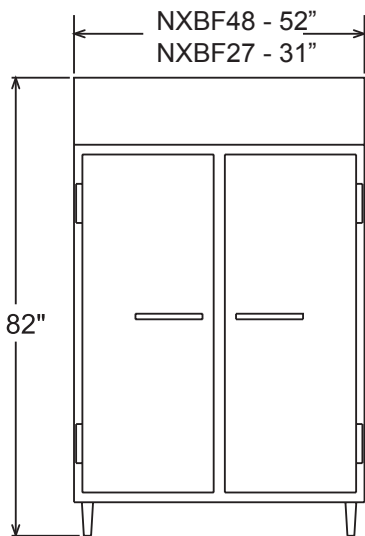

ELEVATION VIEW

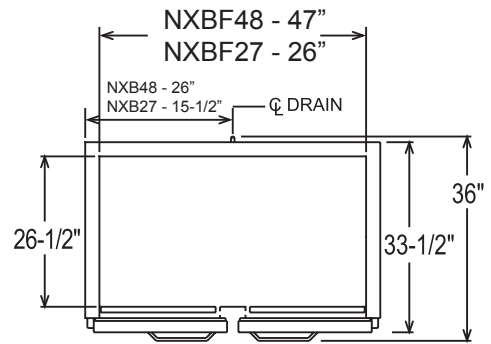

PLAN VIEW

SPECIFICATIONS

<i>Model</i>	<i>NXBF27</i>	<i>NXBF48</i>
<i>Crated Height</i>	85"	85"
<i>Crated Width</i>	35-1/2"	60-1/2"
<i>Crated Depth</i>	40"	40"
<i>Crated Weight (lbs)</i>	490	690
<i>Interior Height</i>	59"	59"
<i>Interior Width</i>	26"	47"
<i>Interior Depth</i>	24-7/8"	24-7/8"
<i>Overall Height</i>	82"	82"
<i>Overall Width</i>	31"	52"
<i>Overall Depth</i>	36"	36"
<i>Number of Shelves</i>	4	8
<i>Number of Legs</i>	4	4
<i>Condensing Unit Size</i>	1HP	1 1/2HP
<i>Refrigerant</i>	R-404A	R-404A
<i>Electrical Characteristics</i>	208-230/60/1	208-230/60/1
<i>Cord & Plug Furnished</i>	Yes	Yes
<i>Maximum Fuse Size</i>	20	20
<i>Total Amp Draw</i>	7.4	11.5

Specifications subject to change without notice.



Revision Date: 01/13
 © 2013 Nor-Lake, Inc.
 Printed in the U.S.A.
 Part Number: 143390

