

Project \_\_\_\_\_

Item \_\_\_\_\_

Quantity \_\_\_\_\_

## ASMP-36 Roll-In Rack Proofer



### SIZE:

**ASMP-36** - 89" High, 69-3/8" Wide, 37-3/8" Deep  
2261 mm High, 1762 mm Wide, 949 mm Deep

NU-VU's ASMP-36 roll-in rack proofer features heavy-duty stainless steel construction, with solid doors. These units also feature the AutoMist humidity system. While these units do not come standard with a roll-in rack, they are available as an accessory item.

### CONSTRUCTION:

- Welded stainless steel
- Fully insulated
- Control panel accessible through front and top of unit
- Heating elements accessible inside of cabinet and through top

### CONTROLS:

- Solid state controls
- Indicator light for thermostat

### STANDARD FEATURES:

- Stainless steel construction
- Solid door
- Solid state controls
- AutoMist humidity system

### OPTIONAL FEATURES:

- Stainless steel roll-in rack

NU-VU® ASMP-36 Roll-In Rack Proofer

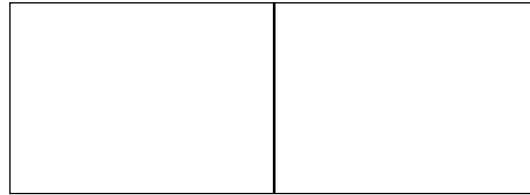

Approval / Stamp

## ASMP-36 Roll-In Rack Proofer

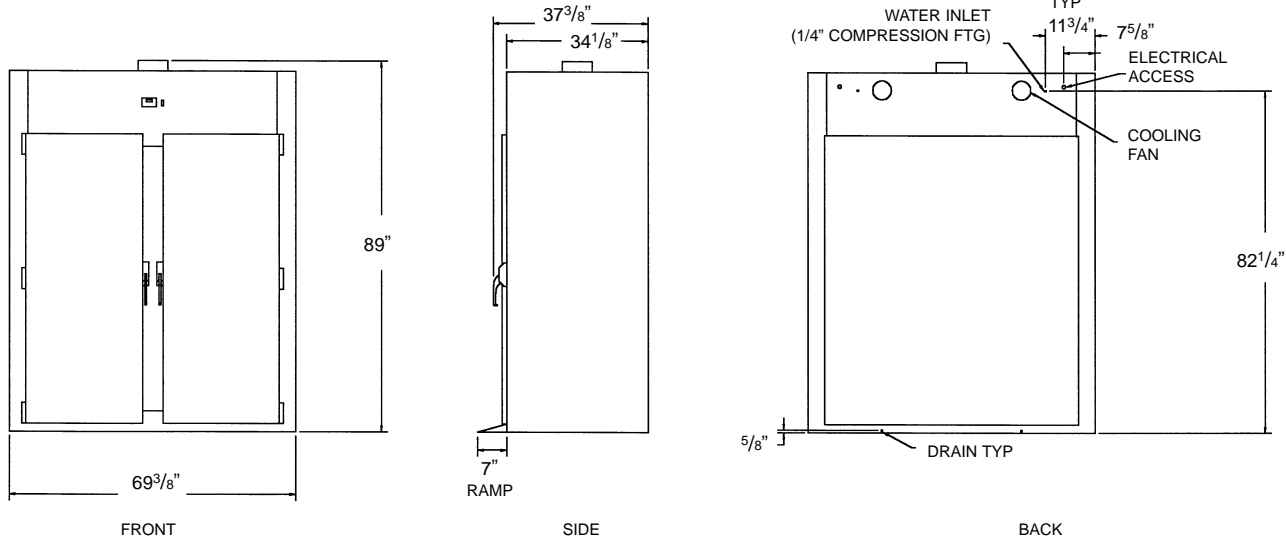

**SPECIFICATIONS:**

**ELECTRICAL:**

**SERVICE CONNECTIONS:**

- Unit is shipped from factory to be hard wired on site. Single phase uses four-wire system.
- 120/208 or 120/240-Volt single phase is standard. Please specify at time of order.
- A 1/4" waterline is required. A water softening system should be used to minimize mineral build-up.

**ELECTRICAL:**

| Amp Draw | 120/208/1 | 120/208/3 | 120/240/1 | 120/240/3 |
|----------|-----------|-----------|-----------|-----------|
| L1       | 19        | n/a       | 19        | n/a       |
| L2       | 16        | n/a       | 16        | n/a       |

**INSTALLATION:**

Allow four inches on each side and back of unit for ventilation of oven.

**CAPACITY:**

|         | 18"x26"<br>Sheet Pans | 13"x18"<br>Sheet Pans | Spacing |
|---------|-----------------------|-----------------------|---------|
| Proofer | 18                    | 36                    | n/a     |

**DIMENSIONS:**

|          | Height                            | Width                             | Depth                             |
|----------|-----------------------------------|-----------------------------------|-----------------------------------|
| Exterior | 89"                               | 69- <sup>3</sup> / <sub>8</sub> " | 37- <sup>3</sup> / <sub>8</sub> " |
| Interior | 75- <sup>1</sup> / <sub>4</sub> " | 61- <sup>1</sup> / <sub>2</sub> " | 32- <sup>3</sup> / <sub>4</sub> " |

**DOOR SWING:** Proofer - 31-<sup>1</sup>/<sub>2</sub>" (800 mm)

**PACKING SIZE:**

83" High, 60" Wide, 38" Deep  
(2108 mm High, 1524 mm Wide, 965 mm Deep)

**SHIPPING WEIGHT:**

1030 Pounds (467 Kg), FOB Menominee, MI 49858

**NU-VU® ASMP-36 Roll-In Rack Proofer**