

Project \_\_\_\_\_  
 Item No \_\_\_\_\_  
 Quantity \_\_\_\_\_

**DCOT5**  
**COUNTERTOP OVEN**



**ELECTRIC (DCOT5)**

- 1 PH - 208V - 21 A - 4 kW - 60 Hz - 2 wires + Ground
  - 1 PH - 240V - 18 A - 4 kW - 60 Hz - 2 wires + Ground
- Other voltages available. Please contact factory for more information.*

**STANDARD FEATURES**

- Programmable touch screen
- Two speed fan
- Door switch cutoff for fan blower
- Stainless steel construction
- 4" adjustable legs (102 mm)
- Press-fit removable door gasket for easy cleaning
- One-handed door handle operation
- Cool touch door with dual thermal wide view glass
- Lift up removable side racks

**STANDARD PRODUCT WARRANTY**

- 2 year parts 1 year labor limited warranty

**OPTIONS AND ACCESSORIES**

- Wire shelf (98-1227-A)

Please note that this oven comes without shelves. The DCOT5 requires 5 shelves.

**DESCRIPTION**

Doyon is proud to introduce their DCOT5 Countertop Oven. This oven offers great flexibility in very limited space. Constructed of stainless steel, and a full view glass door, the oven is designed to be compact yet heavy-duty. The DCOT5 unit has the capacity of five half-size sheet pans. The unit is available in 208 or 240 Volt.

**PAN CAPACITY GUIDE**

Pan Type	Capacity
13" x 18" Half-size	5



## OVERALL DIMENSIONS

DCO5T 29 1/8" W X 27 7/8" D X 26 7/8" h

Shelf Spacing: 3 1/8" (85 mm)

## ELECTRICAL SYSTEM

1 phase:

208V - 21A - 4 kW - 60 Hz

240V - 18A - 4 kW - 60Hz

## OVEN CAPACITY

5 half size (13"X18" - 330 MM X 457 mm) sheet pans

## FINISH

Stainless Steel

## SHIPPING INFORMATION

180 lb (82 kg)

Electrical service connection is located at the back of the unit.

Specifications and design subject to change without notice.

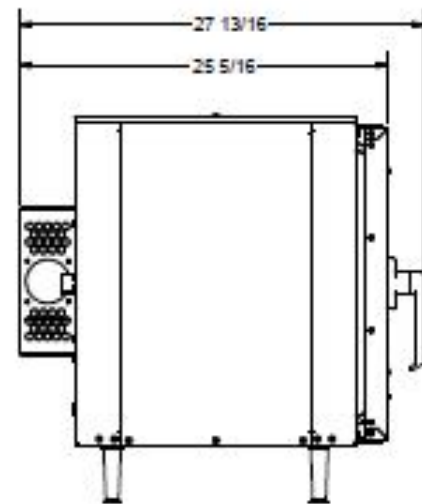
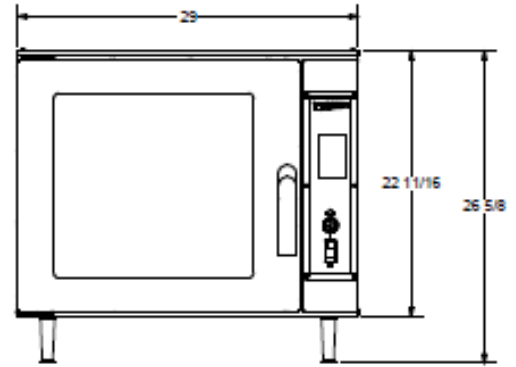

## DOYON & NU-VU

5600 13th Street, Menominee, MI 49858 USA . Phone: 1-800-338-9886 . Fax: (906) 863-5889  
www.doyon.qc.ca . www.nu-vu.com