



5600 13th Street
Menominee, MI 49858
sales@nu-vu.com
1-800-338-9886 Toll Free
1-906-863-4401 Phone
1-906-863-5889 Fax
www.nu-vu.com

Job: _____ Item No. _____

Oven Mounted Ventless Hood

MODEL: NV-WOV35

FEATURES & BENEFITS

- Meets NFPA96 Chapter 4 emissions requirements when used with the NU-VU model X5 all in one oven/proofer.
- Completely self-contained filtration process greatly reduces emissions and cooking aromas.
- Pleated MERV 11 filter & Carbon filter pack.
- Filter pack is easily removable from the front of the hood without the use of tools.
- Air flow sensors continually monitor air flow optimizing performance.
- Optional appliance interlock feature prevents cooking appliance operation if filter pack is missing or clogged.
- Illuminated early warning system to monitor filter replacement.
- Stainless steel outer construction for strength, durability and ease of cleaning.
- Designed to mount directly to top of NU-VU model X5 all in one oven/proofer.
- Limited two-year parts and one year labor warranty.

DESCRIPTION

NU-VU's Oven Mounted Ventless Recirculating Hood System mounts directly to top of the NU-VU model X5 all in one oven/proofer. No venting required to the outside. No additional ductwork required.

This Type II hood is designed for use when proofing and baking breads and other bakery products and is not approved for meats and other proteins.

OPTIONS & ACCESSORIES

- Pleated filter/carbon filter pack Part No. NV-WL0652

MODEL WOV35 OVEN MOUNTED VENTLESS HOOD

MODEL	VOLTAGE AC 50/60 HZ	AMPS 1 PH	HORSE POWER	KW	TYPICAL AIRFLOW	CLEARANCE TO COMBUSTIBLES	CORD & PLUG	WEIGHT
NV-WOV35-120	120	1.0	1/12	0.12	290 CFM	N/A	6 FT NEMA 5-15P	445 lbs
NV-WOV35-230	230	.56	1/12	0.12	270 CFM	N/A	8FT IEC, CEE-7 EURO	445 lbs

SPECIAL ENVIRONMENTAL NOTICE: THE HOOD SYSTEM IS DESIGNED TO GREATLY REDUCE EMISSIONS AND COOKING AROMAS. AIR EXCHANGE AT THE INSTALLATION SITE MUST COMPLY WITH REQUIREMENTS OF THE LOCAL JURISDICTIONAL AUTHORITY.

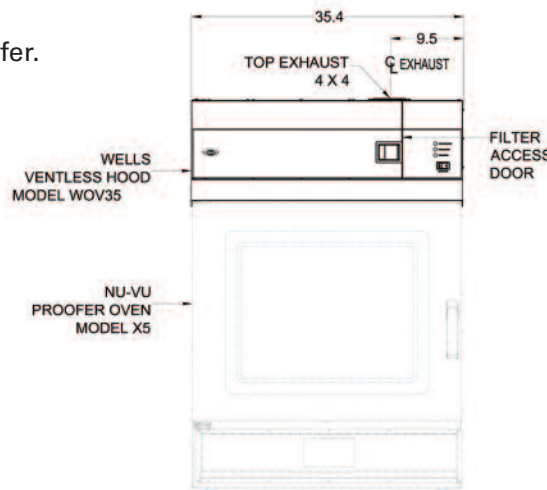

FRONT VIEW

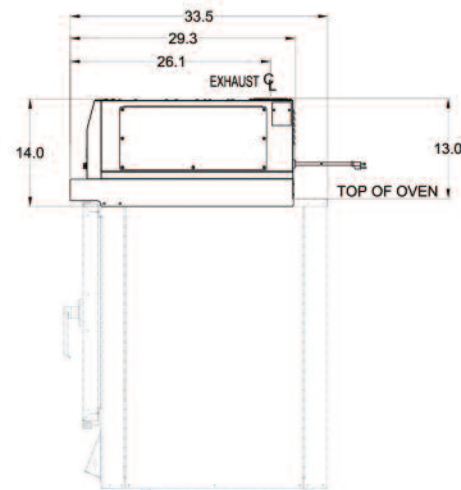

SIDE VIEW

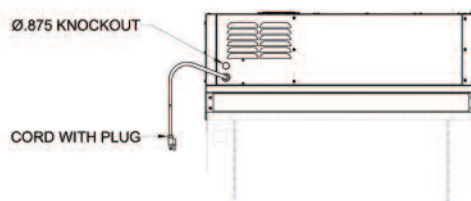

REAR VIEW

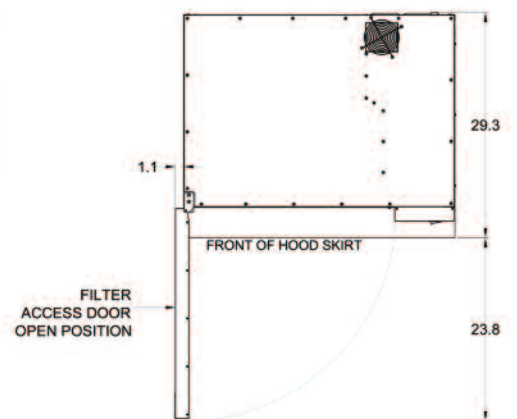

TOP VIEW

