



Project _____

Item No. _____

Quantity _____

X5 ALL IN ONE OVEN/PROOFER

5 PAN CAPACITY - TOUCH SCREEN PROGRAMMABLE CONTROL



ELECTRIC

- 1 PH - 208V - 50 A - 10.4 kW - 60 Hz - 2 wires + Ground - NEMA 6-50P
- 1 PH - 240V - 50 A - 10.4 kW - 60 Hz - 2 wires + Ground - NEMA 6-50P
- 3 PH - 208V - 30 A - 10.4 kW - 60 Hz - 3 wires + Ground - NEMA 15-30P
- 3 PH - 240V - 30 A - 10.4 kW - 60 Hz - 3 wires + Ground - NEMA 15-30P

DESCRIPTION

The all new NU-VU X5 has exclusive patented technology that allows you to proof, bake and steam in the same cavity. Save time and labor by not needing to continually return to the unit and move product from the proofer cavity to the oven cavity.

An added steam function allows you to do all types of products including artisan style breads.

The sleek new look and cool-to-the touch door allows you to use the unit in front of the customers to visually upsell your fresh product and increase sales.

FEATURES & BENEFITS

- Sleek new look
- Cool-to-touch door for added safety
- Easy to use programmable controls
- Wi-Fi capabilities
- Patented technology

| Sheet Pans | 13"x18" | 18"x26" | Spacing |
|------------|---------|---------|---------|
| Oven | 10 | 5 | 4 1/2" |

X5

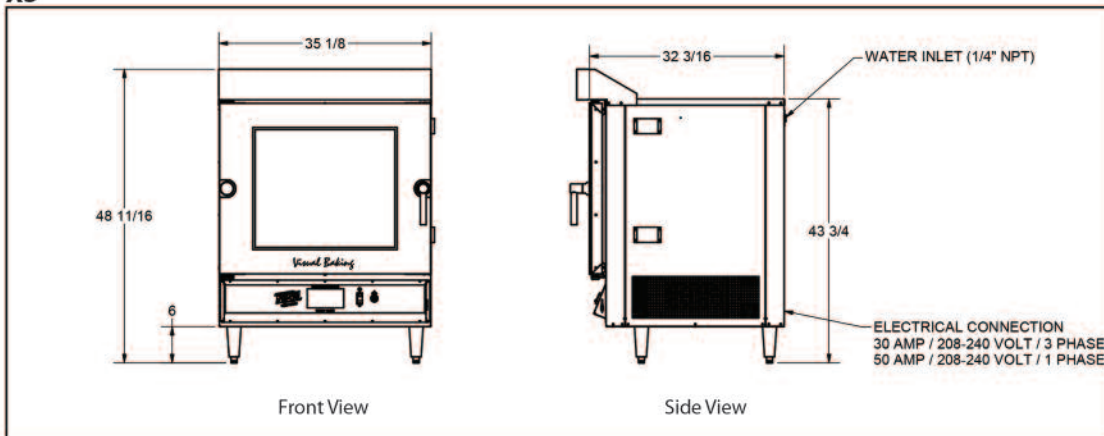

STANDARD PRODUCT WARRANTY

2 year parts, 1 year labor limited warranty

X5 Specs

| Model | Overall Dimensions | | | Interior Dimensions | | | Shelf spacing | Clearance | | | Water Inlet | Shipping Weight | Freight Class |
|-------|--------------------|-------------------|----------------------|---------------------|--------------|------------------|---------------|-------------|-------------|-------------|-------------|--------------------|---------------|
| | W | D | H | W | D | H | | Side | Top | Bottom | | | |
| X5 | 35 1/8" (892) | 32 3/16" (818) | 48 11/16" (1 237) | 28" (711) | 20" (508) | 23 1/4" (591) | 4 1/2" | 4" (102) | 4" (102) | 4" (102) | 1/4" | 635 lb (288 kg) | 85 |

NU-VU FOODSERVICE SYSTEMS

5600 13th Street, Menominee, MI 49858 USA • Phone: 1-800-338-9886 • Fax: 906-863-5889

www.nu-vu.com

