

DROP-IN ICE CREAM UNIT

Perlick Features

- Mounts into Countertop.
- Maintains proper ice cream temperature.

MODEL NOS.

Drop-In Series

8000

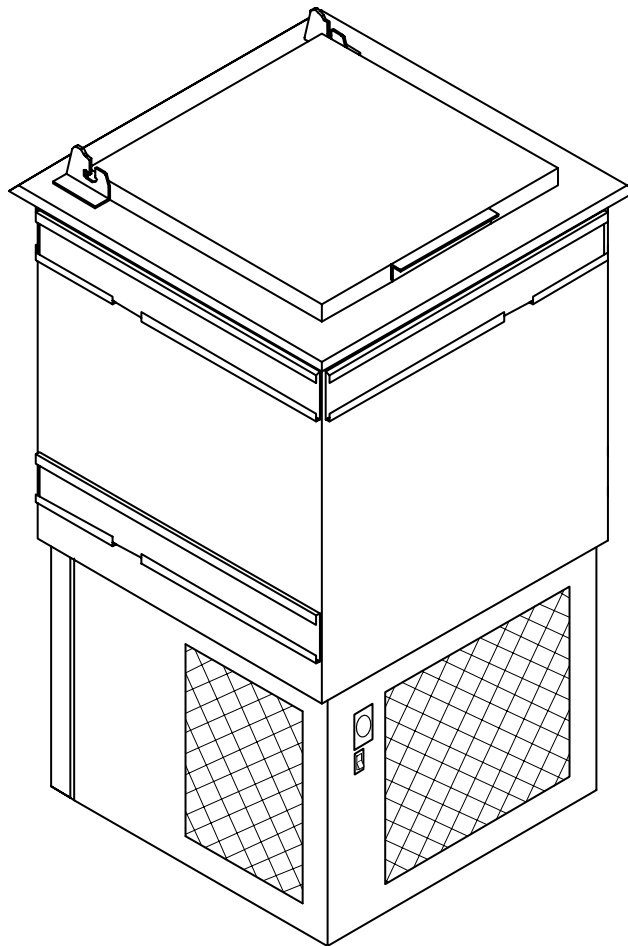

8300 West Good Hope Road • Milwaukee, WI 53223 • Phone 414-353-7060 • Fax 414-353-7069
Toll Free 800-558-5592 • E-Mail: Perlick@Perlick.com • www.Perlick.com

Sizes and Specifications Drop-In Ice Cream Unit

Job _____
 Area _____
 Item No. _____
 Model No. _____



MODEL NOS.	8000
CAPACITY	3 Gallons
DIMENSIONS In. [mm]	
HEIGHT	26 ³ / ₄ " [680]
WIDTH	16 ¹ / ₈ " [410]
DEPTH	16 ¹ / ₈ " [410]
SHIP WEIGHT lbs. (kg)	114 (52)
COMPRESSOR H.P.	1/6 h.p.
AMPS	1.6
INTERIOR	Well dimensions: 13 ⁵ / ₈ " [346] H x 10 ¹ / ₄ " [260] W x 10 ¹ / ₄ " [260] D.
EXTERIOR	20 gauge stainless steel top and removable hinged door lid.
ELECTRICAL	115 Volt, 60 Hz., 1 Phase AC. Furnished with three-prong, six foot rubber cord and on/off switch.
REFRIGERANT AND CHARGE	R134a 5.5 oz. (142).

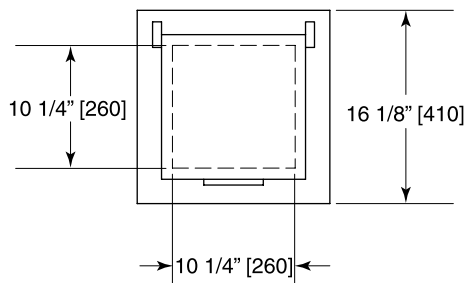

CUT-OUT REQUIRED
 15 1/4" x 15 1/4" [39 x 39]

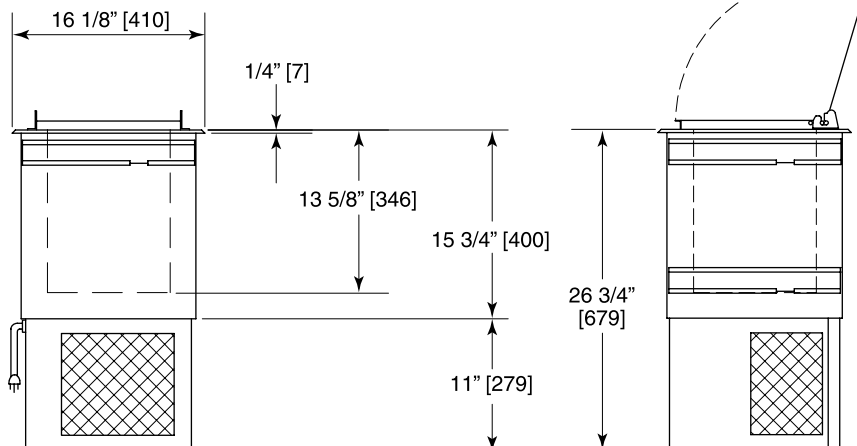

8300 West Good Hope Road • Milwaukee, WI 53223 • Phone 414-353-7060 • Fax 414-353-7069
 Toll Free 800-558-5592 • E-Mail: Perlick@Perlick.com • www.Perlick.com

Perlick is committed to continuous improvement. Therefore, we reserve the right to change specifications without prior notice.

Form No. DC02
 Rev. 08.22.07