

The 40/4 Chair

by OSI Furniture



Revered for its sculptured design, unsurpassed in stacking abilities, and praised for its durability, the 40/4 chair has won countless awards and proven itself as one of the most versatile and recognizable stacking chairs since its design in 1964 by David Rowland.





Wood Veneer

Our unique Demi-Glaze is created by hand swirling an optical pattern onto the seats and backs and coating them in a transparent paint that brings the pattern to life.

The Demi Glaze is a striking chair like no other, a must see to believe.





40 stacked on dolly,
sold separately



Stack and store
chairs effortlessly.
40 chairs easily
stack 4 feet high.



Gentle, contoured
lines disguise the
40/4 chair's rugged
durability.





The sleek and comfortable design of the 40/4 chair enjoys the addition of a sliding tablet arm and book rack, creating compact student seating perfectly suited for today's educational field.



Leather



Enjoy the added comfort and design flexibility of the upholstered 40/4 chair—perfect for waiting rooms, meeting areas, lobbies, and more.

Ganging
Upholstery



ST. PAUL'S CATHEDRAL, LONDON



Ronald Reagan UCLA
Medical Center



Counter height



NEW!

Bar and Counter Height 40/4 Chairs



Now, there is no application the 40/4 cannot fulfill. The award-winning design of the 40/4 chair is available in two additional heights: bar and counter. Both new chair heights are just as comfortable and aesthetically pleasing as the standard height chair and are, of course, **STACKABLE!** All the current paint, wood veneer and upholstery options are available for the taller chairs.

Options

Painted Steel



Tablet Arm,
Bookrack



Dolly



Upholstery



Wood/Upholstery
Hybrid



Demi-Glaze



Wood Veneer



Leather



Ganging



*All 40/4 chairs are standard in either a chrome or black frame.

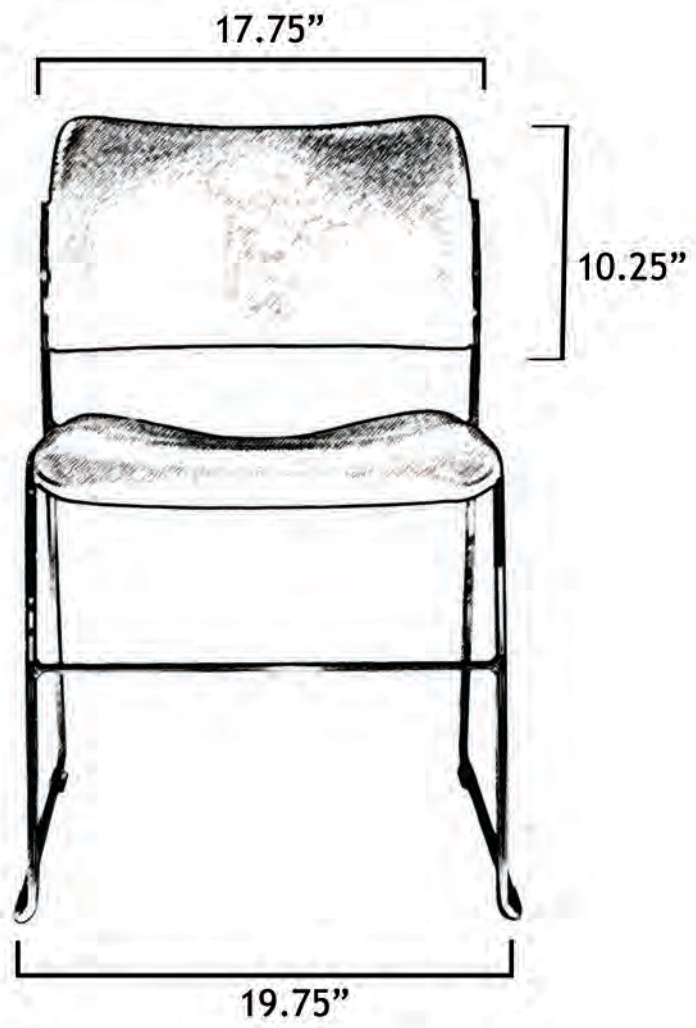

Standard Height

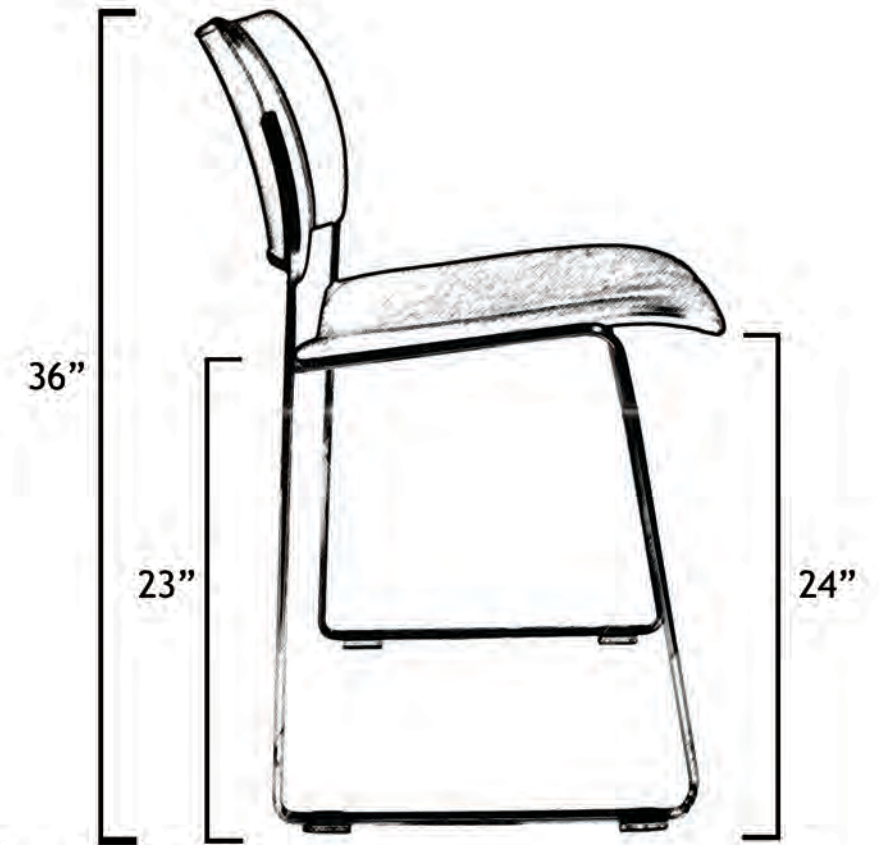

Counter Height

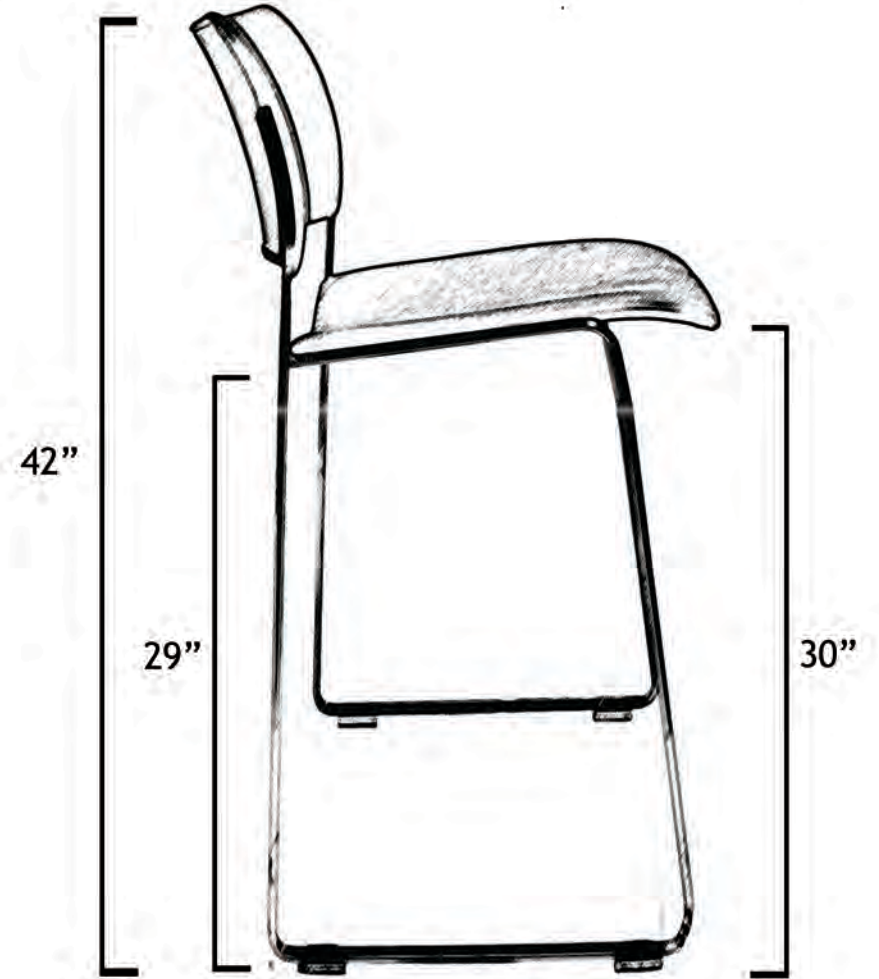
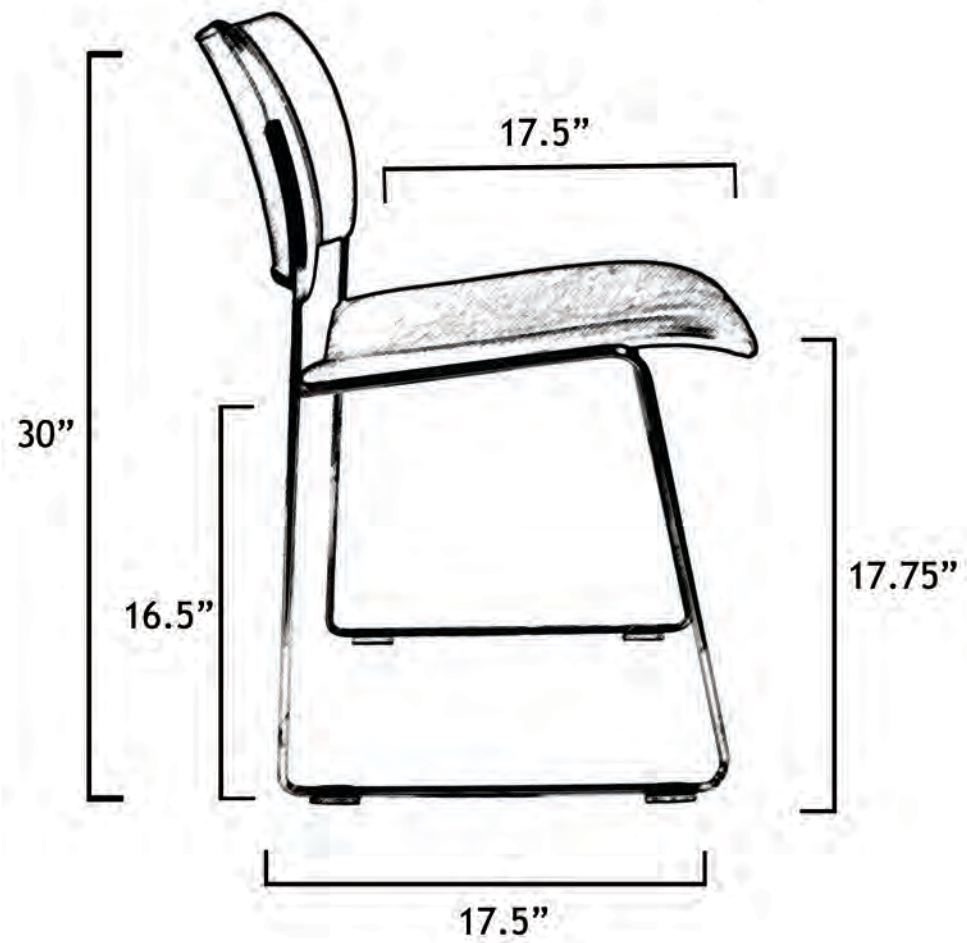

Bar Height

40/4 Chair Awards:

1964: Grand Prix, Milan Triennale for 40/4 Chair (one of only two Americans to receive this award, the other one being Buckminster Fuller for his Geodesic Domes).

1965: American Institute of Designers (AID) award for best piece of business furniture.

1965: Product Engineering Magazine Award, 40/4 Chair (one of 12 best products introduced in the United States in 1965).

1969: Austrian Gold Medal Award for furniture.

1979: Institute of Business Designers (IBD) Gold Medal for best product in Special Seating Category.

1979: Institute of Business Designers (IBD) Gold Medal for best product of entire awards competition.

1980: International Council of Societies of Industrial Design (ICSID) Exhibition, Milan, Italy.

1984: 'Design in America: The Cranbrook Vision 1925-1950'.

1992: Metropolis Magazine recognized the 40/4 as one of the Classic Designs from around the World - of the Past 50 Years.

40/4 Permanent Collections:

New York: Museum of Modern Art, Cooper-Hewitt Museum of Design, Metropolitan Museum of Art, The Brooklyn Museum

London: The Design Museum

Paris: Musée des Arts Decoratifs, Palais du Louvre

Chicago: Art Institute of Chicago

Montreal: Musée des Arts Decoratifs

Weil Am Rhein: The Vitra Museum

Munich: Die Neue Sammlung

Rio De Janeiro: Museu de Arte Moderna

Flint: Institute of Fine Arts

Philadelphia: Philadelphia Museum of Art

Cranbrook: Cranbrook Academy of Art Museum



portable.
stackable.
storable.

1050 Chinoe Road
Lexington, KY 40502
800-762-0415
www.psfurniture.net