



PREPARATION TABLE

DUAL-RAIL, RAISED & ELEVATED RAIL MODEL 8148D

The 8148D dual-rail prep table provides double the topping pan capacity of a traditional style prep table, maximizing your left to right footprint. Both pan rails operate independently of one another and are designed to meet the ANSI/NSF-7, 41°F pan product temperature requirements. Our system separates both rails and the base to assure proper temperatures in all three zones. This allows the rails to be shut off (independently) to maximize energy savings overnight while storing the food product in the base of the unit or your walk-in. Each rail is outfitted with an over-sized drain allowing for easy and convenient cleaning after the last shift.

STANDARD FEATURES:

- Meets ANSI/NSF-7, 41°F product temperatures in rails
- Recessed cold-wall conductive cooling cascades a cold blanket of air over the food to assure proper temperatures without drying out food
- Each rail is managed with its own on/off switch and thermostatic control, giving the operator full access to adjustments as needed
- The base is run separately with its own thermostatic control eliminating compromise between base and food pan temperatures
- Rails can be shut down (independently) at night for cleaning and energy savings – up to 60% energy savings over 24 hours
- Each rail is supplied with the industries only standard over-sized drain – valve is behind hinged louver door
- Hinged louver provides easy access to preventative maintenance coil cleaning, drain access, and on/off switch and t-stats for both rails
- Press-fit gaskets make preventative maintenance and replacement easier than ever – without tools

CABINET EXTERIOR: Unit top and raised rail will be formed from four piece 20 gauge stainless steel with a 1-1/2" 90° nosing/top turndown. The raised refrigerated rails will be mechanically cooled and shall be provided with one single opening to allow flexible pan configurations. The interior of the rails will be constructed of three-piece construction with coved corners for easy cleaning. Rails will hold 6" deep pans - not included. The pans will sit on an integral recessed pan ledge (1" at front and 3" at rear) making clean-up easy without requiring the removal of any pan supports. All units provided with hinged removable stainless steel covers, fabricated from 20 gauge stainless steel, and supplied with a combination of covers which allow maximum access to the pans. Unit bottom and exterior back are galvanized metal. Exterior ends are finished in stainless steel. New hinged louver for easier cleaning of the coil and draining the rails. Unit mounted on 4" (overall) high swivel casters (front two with locks).

CABINET BASE INTERIOR: Interior floor, rear and top shall be anodized aluminum. Base interior ends and door openings shall be thermoformed high impact ABS. Each section will be provided with (1) removable interior epoxy-coated wire shelf. The base shall be foamed in place polyurethane insulation with a minimum thickness of 2".

DOORS: Stainless steel front with easy to grasp handles. Doors mounted on heavy duty stainless steel concealed type hinges with pivot pin in nylon bushing. Door interior is deep drawn thermoformed high impact ABS with press-fit replaceable magnetic gaskets, designed for long life and easy maintenance. Doors are foamed in place polyurethane insulation.

REFRIGERATION SYSTEM: The system will utilize R-404a refrigerant and be provided with a hot gas condensate evaporation system. Dual refrigeration system with independent controls for the base and the rails. The base will have a blower coil with a dedicated metering device and solenoid valve allowing the thermostatic control to independently control the base temperature. The raised mechanically cooled rails will be controlled utilizing an expansion valve metering device with its own solenoid valve and thermostat. An on/off switch, located directly behind the hinged louver, is provided as standard to allow the rail to be shut off independently of the base. A pressure control is provided to monitor the dual systems performance.

ELECTRICAL: The units will be provided with a 8' power cord and 3-wire grounded plug as standard, pre-wired for 115 volt, 60 hertz, single phase operation. Export voltages are available and require hard wiring in the field to the units main junction box, (unit will be shipped on legs for export applications, unless specified otherwise). This equipment is intended for use in rooms having an ambient temperature of 86°F (30°C) or less.

ORIGIN OF MANUFACTURE: Designed and manufactured in the United States.

PROJECT NAME:

LOCATION:

ITEM NO:

QTY:

MODEL NO:

AIA NO:

SIS NO:

CSI SECTION: 11400

Model 8148D shown.



OPTIONS/ACCESSORIES:

- Patented double drawer cartridges
- Cutting boards
- Stainless steel back
- Pull-out catch pan assemblies
- Tray racks for 18 x 26 sheet pans

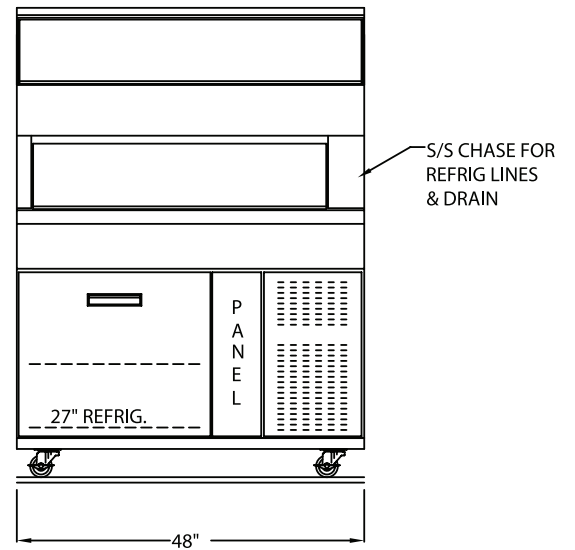
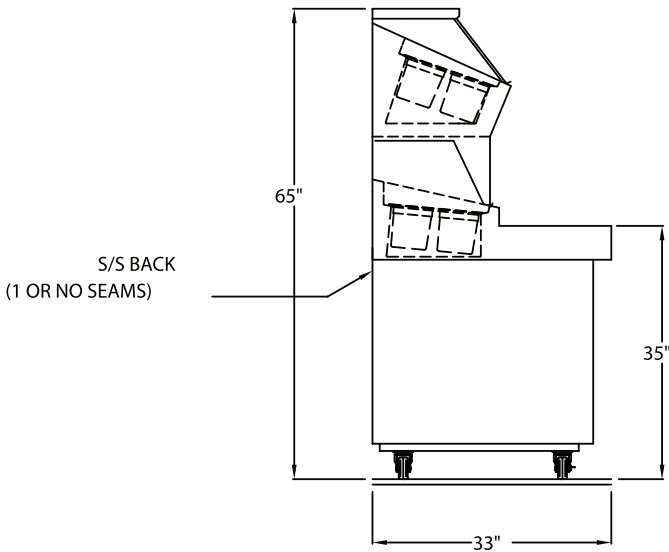
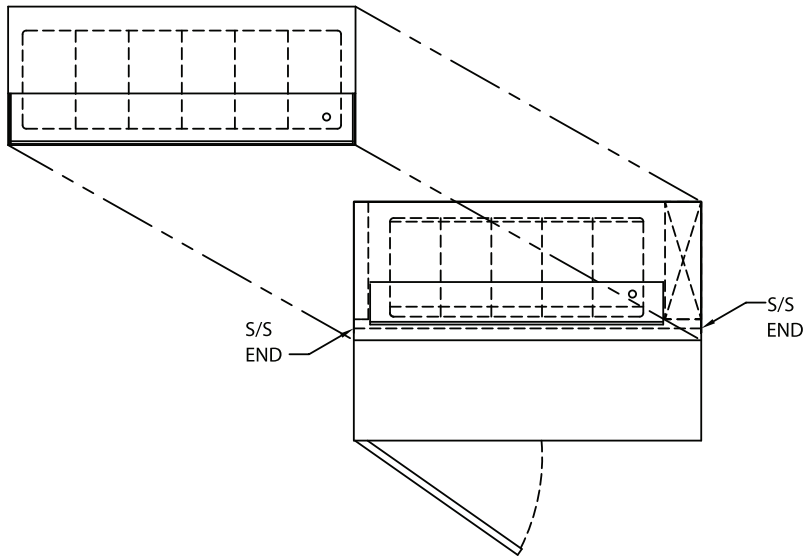
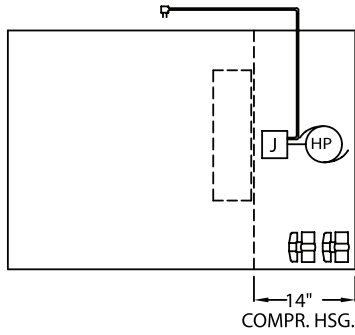

DOOR OPENING SIZE- INTERIOR DEPTH

Door Width	Clearance (Lt to Rt)	Clearance (Tp to Btm)	Interior depth behind door
27"	22"	20.5"	26"

Model	L	W	H	Doors	Storage Cu. Ft.	Pan Capacity	Volt	NEMA	Ship Wt.
8148D	48"	33"	65"	(1)27"	9.0	(11)1/3	115/60/1	5-15P	450