

# Drop-In Hot/Cold Combination Food Well models 9580

model  9580-2A  9580-3A  9580-4A  9580-5A  9580-6A

### Description:

Drop-in self-contained, cold pan / heated food well unit. With the flip of a switch, this unit is converted from a hot breakfast buffet to a cold salad bar for lunch, or any other use. One piece stainless steel top and coved corner interior. Controls, cordset & louver panel provided. True thermostatic control for hot operation. R-404a refrigeration system is "CFC free".

### Specifications:

**UNIT TOP:** Top and water bath tank to be one piece, 16 gauge stainless steel.

**UNIT BODY:** Fully insulated, exterior body to be corrosion resistant steel. Unit sidewalls feature wrapped refrigeration lines with foamed in place polyurethane insulation, unit bottom fitted with heating elements, fiberglass insulation and shield. Interior fitted with 1" drain at one end. Drain nipple supplied with gate valve. 1" high perforated stainless steel bottom strainer plate(s) provided for cold pan use. Condensing unit mounted on corrosion resistant framework, suspended below unit body.

**CONTROLS:** Controls prewired to junction box mounted on separate stainless steel panel for field installation in counter front. Connections to heating elements to be located outside of heated zone to avoid wiring deterioration. Hard wire connection required for hot food well operation.

### Standard Features:

- The same unit can now be used for hot or cold food applications

### Standard Features: COLD USE

- All stainless steel top
- Drain & gate valve standard (Note: gate valve shipped loose for field installation by others)
- Stainless, perforated bottom strainer plates provided
- Wrapped, coldwall construction refrigeration
- Stainless steel louver panel provided
- R-404a refrigerant, "CFC free"

model 9580-3A shown



### Standard Features: HOT USE

- All stainless steel top
- Open tank Baine Marie style for wet operation
- True thermostatic control for precise food temperatures
- Drain and gate valve

### Options & Accessories:

- Adaptor bars
- Remote on/off switch
- Extended thermostatic lead

For use with ice. Provided with cooling system to reduce ice usage.

**LEGEND FOR MODEL # 9580-2A**  
 (1) ELEMENT, 1100 WATTS  
 REQUIRES HARDWIRE CONNECTION  
 □ 120/208V-60Hz-1Ph 5.3Amps  
 □ 120/240V-60Hz-1Ph 4.5Amps  
 1/4hp COMPRESSOR  
 D 1" DIA DRAIN LINE CONNECTION  
 1" FPT AT 24" AFF

**LEGEND FOR MODEL # 9580-3A**  
 (2) ELEMENTS, 2200 WATTS  
 REQUIRES HARDWIRE CONNECTION  
 □ 120/208V-60Hz-1Ph 10.6Amps  
 □ 120/240V-60Hz-1Ph 9.2Amps  
 1/4hp COMPRESSOR  
 D 1" DIA DRAIN LINE CONNECTION  
 1" FPT AT 24" AFF

**LEGEND FOR MODEL # 9580-4A**  
 (3) ELEMENTS, 3300 WATTS  
 REQUIRES HARDWIRE CONNECTION  
 □ 120/208V-60Hz-1Ph 15.9Amps  
 □ 120/240V-60Hz-1Ph 13.3Amps  
 1/4hp COMPRESSOR  
 D 1" DIA DRAIN LINE CONNECTION  
 1" FPT AT 24" AFF

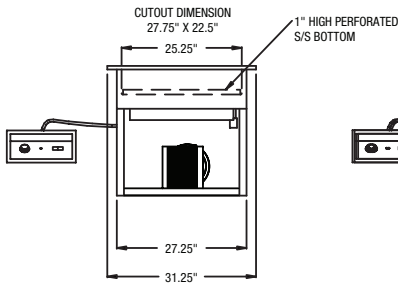
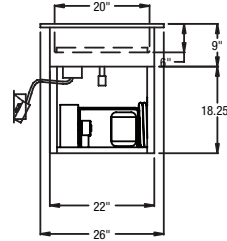
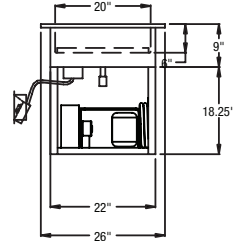
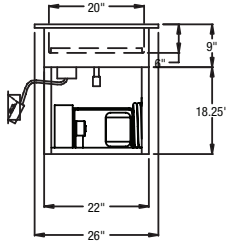

MODEL #9580-2A

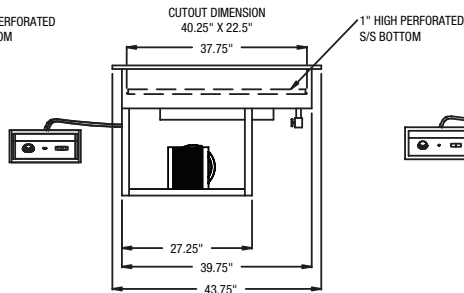

MODEL #9580-3A

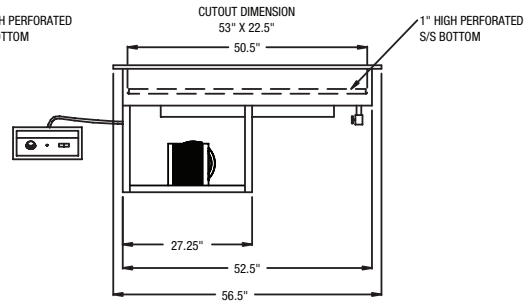

MODEL #9580-4A

**LEGEND FOR MODEL # 9580-5A**  
 (4) ELEMENT, 4400 WATTS  
 REQUIRES HARDWIRE CONNECTION  
 □ 120/208V-60Hz-1Ph 21.2Amps  
 □ 120/240V-60Hz-1Ph 18.3Amps  
 1/4hp COMPRESSOR  
 D 1" DIA DRAIN LINE CONNECTION  
 1" FPT AT 24" AFF

**LEGEND FOR MODEL # 9580-6A**  
 (5) ELEMENT, 5500 WATTS  
 REQUIRES HARDWIRE CONNECTION  
 □ 120/208V-60Hz-1Ph 31.4Amps  
 □ 120/240V-60Hz-1Ph 27.9Amps  
 1/4hp COMPRESSOR  
 D 1" DIA DRAIN LINE CONNECTION  
 1" FPT AT 24" AFF

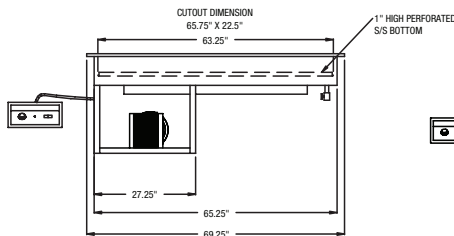
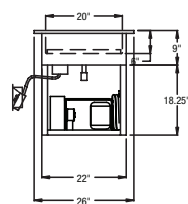
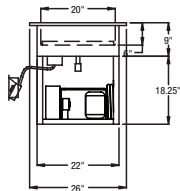

MODEL #9580-5A

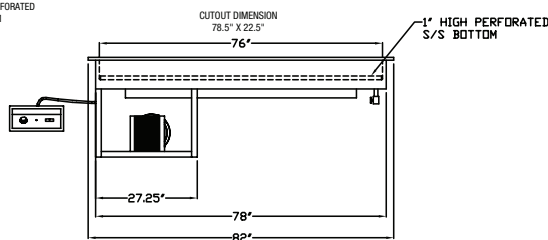

MODEL #9580-6A

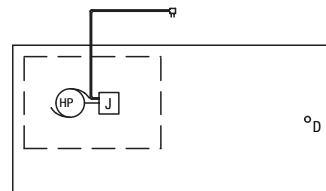

Model	L	D	12"x20" Pan Cap.	Cut Out Size		No. of Elements	Watts	H.P.	Amps / 60 / 1 PH			Ship Wt.
				Unit	Control Panel				120V (Refrig.)	208V (Heated)	240V (Heated)	
9580-2A	31 1/8"	26"	2	27 3/4" x 22 1/2"	14" x 6"	1	1100	1/4	5.3	5.3	4.5	110
9580-3A	43 5/8"	26"	3	40 1/4" x 22 1/2"	14" x 6"	2	2200	1/4	5.3	10.6	9.2	135
9580-4A	56 1/2"	26"	4	53" x 22 1/2"	14" x 6"	3	3300	1/4	5.3	15.9	13.8	160
9580-5A	69 1/4"	26"	5	65 3/4" x 22 1/2"	14" x 6"	4	4400	1/4	5.3	21.2	18.3	185
9580-6A	82"	26"	6	78 1/2" x 22 1/2"	14" x 6"	5	5500	1/4	5.3	31.4	27.9	210

Requires 120 / 240V or 120/208V (4 wire) power supply hard wiring to "J" box. 120V refrigeration system - 208/240V heating system.



Component