



FX Series Preparation Work-Top System model FX-2WSRE

THE MOST REVOLUTIONARY, ENERGY-EFFICIENT, FLEXIBLE, FOOD-SAFE REFRIGERATION SYSTEM

Description:

- Flexible Refrigeration
- Energy Efficiency
- Food Safety

Two refrigerated Inserts with finished top; on casters. The FX Series revolutionizes point of use refrigeration by allowing the operator to adjust the temperatures from 0°F (freezer) operation up to 40°F (refrigerator) or any setting in between utilizing its unique convertible refrigeration system. Using a patented technology that provides 100% in-drawer cooling, this ultra-efficient self-contained system provides precise temperature control without compromising operator flexibility.

Specifications:

REFRIGERATION SYSTEM: The FX Series uses a patented in-drawer cooling system that directs 100% of the cooling inside the insulated and removable drawer Insert (see below). The evaporator coil is mounted horizontally above the drawer Insert with an integral gasket that seals against the insulated drawer compartment when closed. The refrigeration system operates only when the drawer is closed, efficiently managing the air-flow while reducing energy and humidity build-up. Press-fit removable gasket with magnet-to-magnet seal is standard.

DRAWER SYSTEM: The FX Series drawer system is the only full-extension, full product view, drawer system that has the drawer tracks outside the cooled compartment offering a more reliable, durable system not prone to the cold or debris environment common in traditional drawer systems. The full-extension tracks are constructed of 12 gauge stainless steel with a fully integrated Insert support system. The drawers slide on self-lubricating Delrin material requiring no lubricating maintenance by the operator. The drawer box and intermediate tracks are removable without tools and can only be reinstalled one-direction for proper fit. The drawer system has been tested with over 300,000 cycles without failure (90 pound test load per drawer).

REMOVABLE INSULATED INSERT: This exclusive design allows full removal of the refrigerated compartment for cleaning or pre-loading. Made of high impact ABS plastic with high density polyurethane insulation. Provides unparalleled insulation value with no air gaps.

TEMPERATURE STATEMENT: The unit is provided with a electronic temperature controller that can be easily adjusted by the operator to any temperature setting between 0°F (freezer) operation up to 40°F (refrigerator).

CABINET EXTERIOR: The cabinet exterior is high grade stainless steel to allow long use and beauty while providing easy to maintain and clean surfaces. Optional Stainless steel tops offer the ability to use the FX Series as a work-top unit or cooking equipment stand.

model FX-2WSRE



CABINET BASE/INTERIOR: The cabinet interior is high grade stainless steel to allow long use and beauty while providing easy to maintain and clean surfaces.

ELECTRICAL: Standard 115 volt with NEMA 5-15 cord and plug; In multi-stack applications, a jumper cable is available to allow up to three units on one wall circuit (three units total).

Standard Features:

- Convertible Refrigeration System (Refrigerator to Freezer)
- Point-of-use Size and Design
- Precise Temperature Control
- Patented In-drawer Cooling System
- Removable Insulated Drawer Compartment
- Ambient Drawer Track System
- Full-Extension Drawer System
- Horizontal Gasket is Out of Harms Way
- Individual Compressor Per Drawer
- Casters

Options & Accessories:

- Leg Kit
- Stainless Steel Back Panel
- Additional Insulated Inserts: Qty. _____
- Pan Racks



TOP VIEW

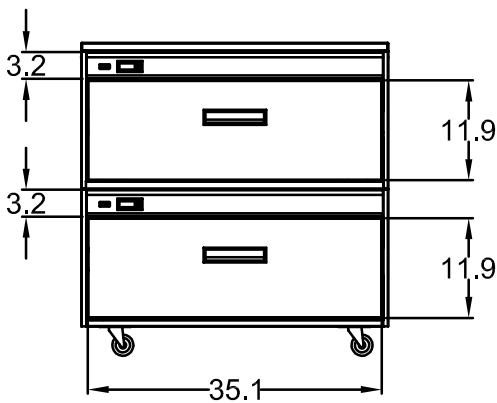
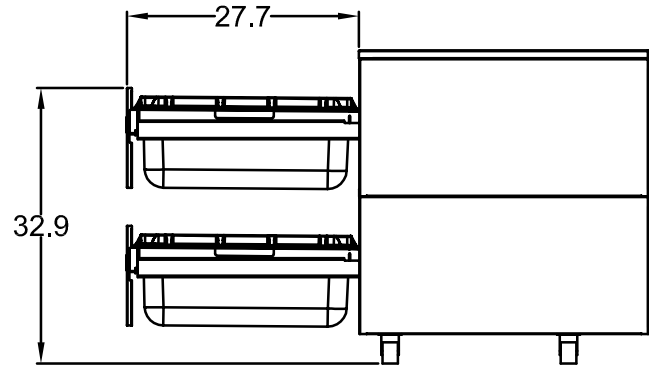

FRONT VIEW

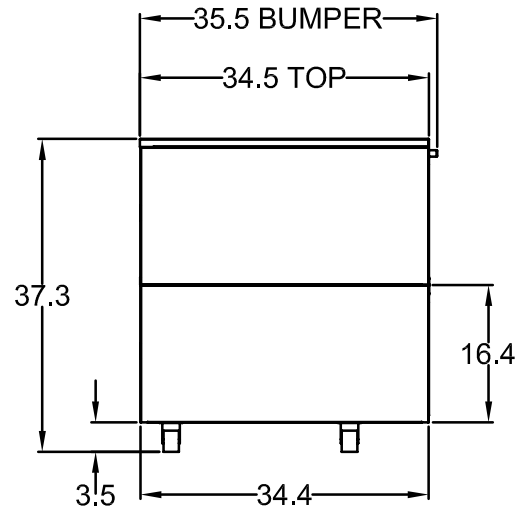

SIDE VIEWS

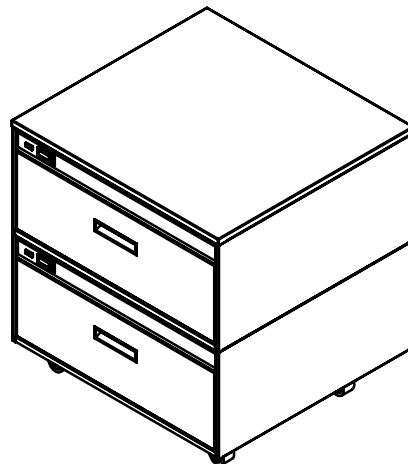
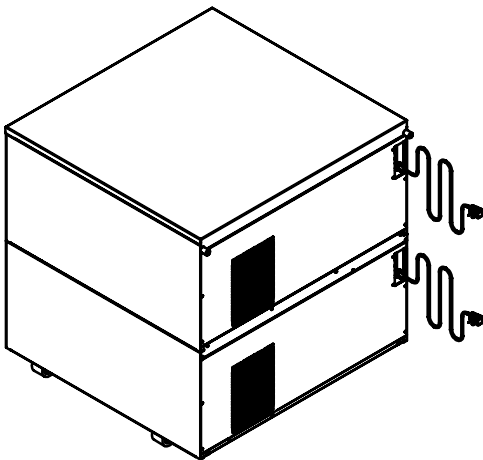

MODEL FX-2WSRE: TWO STACKED UNITS WITH FINISHED TOP; ON CASTERS; REAR COMPRESSOR

L	D	H*	No. of Drawers	Storage (cubic feet)	Comp. Size	Amp Draw (actual)	Refrig. Power Usage (per day)	Freezer Power Usage (per day)	Volt	NEMA	Ship Weight (lbs)
36.75"	34.5"	37.5"	2	6.0	5.5cc each	7.8	2.44kw	3.98kw	115	5-15p	635

* 3.5" casters

