

RANDELL®

RanServe Stainless Steel Cashier Stand models CA

Description:

Portable, stainless steel top cashiers stand. Locking cash drawer, foot rest/shelf, and cash register cord hole. Interchangeable stainless steel or laminate body panels, snap together locking device designed to work with all other RanServe equipment. (4) swivel casters provided.

Specifications:

UNIT TOP: Top to be one piece of die-formed 16 gauge stainless steel with 1 1/2", 90° nosing on all sides.

UNIT BODY: Body frame to be all welded construction of steel with exposed corners to be 1 1/2" stainless steel. All corners welded and polished. Body ends and panels to be plastic laminate with galvanized steel backing (specify laminate color). Body ends and panels to be removable to allow the changing of colors. Unit provided with a stainless locking cash drawer on ball bearings, foot rest/shelf, and cash register cord hole. Unit to be equipped with 4 swivel casters, (2) locking, that are recessed inside of toe area.

Standard Features:

- Interchangeable body panels
- Concealed locking mechanism with easy to use spring-activated catch
- Swivel casters - (2) locking

Options & Accessories:

- Trayslides
- Corian top
- Granite top
- Laminates
- Graphics
- Elementary School Height

model RAN CA shown



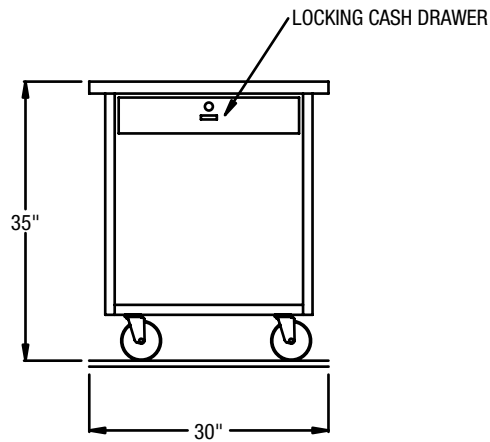
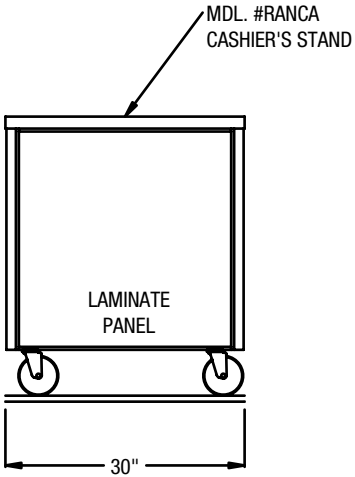
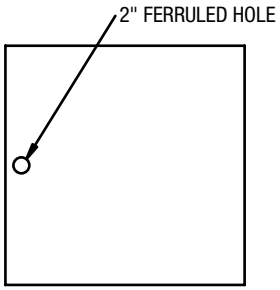

Model	L	D	H	Ship Wt.
RAN CA	30"	30"	35"	135

