



Serving Lines, Fiberglass Cashiers Stand model CA

Description:

Randell's RANFG CA Stainless Steel Top Cashiers Stand designed for virtually any cashiers application, the RANFG CA series is enclosed in brilliant one-piece fiberglass body and 16 gauge stainless steel top.

Specifications:

CABINET CONSTRUCTION: One-piece molded fiberglass body for smooth exterior finish. All corners and areas where accessories are mounted are reinforced internally with metal backers.

TOP CONSTRUCTION: Exterior top is standard in reinforced 16 gauge 300 series stainless steel with #4 finish. Optional 14 gauge tops available at a minimal upgrade

Standard Features:

- Concealed locking mechanism with easy to use spring-activated catch
- Can be rotated to operate either end or front use

Available Fiberglass Colors:

- Pitch Black
- Dark-Bark Brown
- Cabernet Wine
- British Racing Green
- Tin Man Gray
- True Blue
- Light Sky Blue
- Candy Apple Red
- Tiger Lilly Orange
- Canary Yellow
- White

Options & Accessories:

- Canopy
- Overshelves
- Trayslides
- Corian top
- Granite top
- Kick Plate
- Graphics
- Sneeze Guards
- Elementary School Height
- Electrical Distribution System

model RANFG CA shown with optional kick plate and trayslide

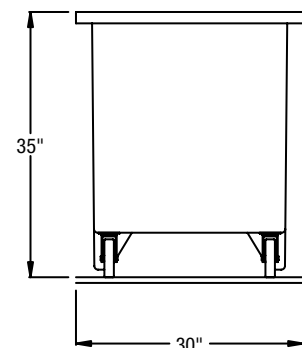
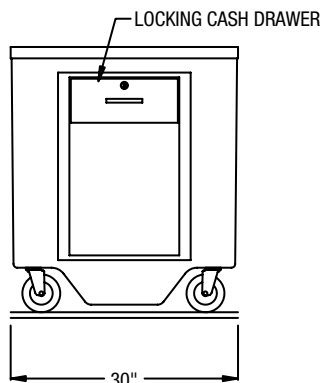
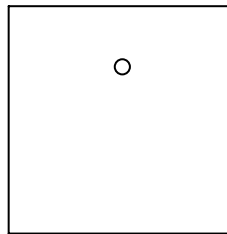

Model	Length	Depth	Height	Ship Wt.
RANFG CA	30"	30"	35"	135