

DFW Deluxe Food Warmer



DFW-100



DFW-200



DFWT-100



DFWT-200

Serve hot food quickly with just the push of a button. The Deluxe Food Warmer uses plain tap water to heat and cook foods. The generator converts water into super-heated dry steam that fully penetrates foods from all sides to keep the original textures, colors, flavors, and nutrients. Use it to prepare a variety of different menu items, including pastas, breads, meats, seafood, poultry, eggs, and vegetables.

Simple push-button action delivers a fully adjustable pulse of steam. Because the amount of steam is consistent, it removes the guesswork and produces a uniform finished product from one operator to the next.

NOTE: Units with a direct water hookup require a water pressure regulator. The psi should be between 20 and 30.

Features

- Compartment steamer with half or two-thirds size pan capacity.
- Stainless steel construction.
- Fully adjustable pulse of steam.
- Consistently finished product.
- Instantly turns plain tap water into super-heated dry steam.
- Models available with either a self-contained water reservoir or direct water hookup.
- Safety steam release valve.



roundup

a brand by A.J. Antunes & Co. www.ajantunes.com

DFW Deluxe Food Warmer

Dimensions

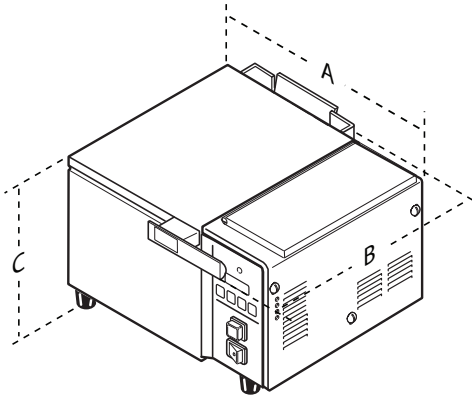

Model No.	Width (A)	Depth (B)	Height (C)
DFW-100	16 5/8" (422 mm)	17 1/4" (438 mm)	8 3/4" (222 mm)
DFW-200	16 5/8" (422 mm)	17 1/4" (438 mm)	8 1/4" (210 mm)
DFWT-100	20" (508 mm)	17 1/4" (438 mm)	8 3/4" (222 mm)
DFWT-200	20" (508 mm)	17 1/4" (438 mm)	8 1/4" (210 mm)

Shipping Dimensions

Model No.	Height	Width	Depth	Weight
DFW-100	12" (305 mm)	21" (533 mm)	21" (533 mm)	45 lbs. (21 kg)
DFW-200	12" (305 mm)	21" (533 mm)	21" (533 mm)	45 lbs. (21 kg)
DFWT-100	13" (330 mm)	25" (635 mm)	21" (533 mm)	55 lbs. (25 kg)
DFWT-200	12" (305 mm)	21" (533 mm)	16" (406 mm)	53 lbs. (24 kg)

Electrical Ratings and Plug Configuration

Model & Mfg. No.	Volts	Watts	Amps	Hertz	Plug Description
------------------	-------	-------	------	-------	------------------

Half Size Pan and Self-Contained Water Tank

DFW-100 9100101	120	1800	15	50/60	NEMA 5-15P 15 Amp., 120 Volt
DFW-100 9100102	120	1500	12.5	50/60	NEMA 5-15P 15 Amp., 120 Volt
DFW-100 9100103	230	2800	12.2	50/60	CEE 7/7 16 Amp., 250 Volt

Half Size Pan and Direct Water Hook-Up

DFW-200 9100111	120	1800	15	50/60	NEMA 5-15P 15 Amp., 120 Volt
DFW-200 9100113	230	2800	12.2	50/60	CEE 7/7 16 Amp., 250 Volt

Two-Thirds Size Pan and Self-Contained Water Tank

DFWT-100 9100121	120	1800	15	50/60	NEMA 5-15P 15 Amp., 120 Volt
DFWT-100 9100123	230	2800	12.2	50/60	CEE 7/7 16 Amp., 250 Volt

Two-Thirds Size Pan and Direct Water Hook-Up

DFWT-200 9100131	120	1800	15	50/60	NEMA 5-15P 15 Amp., 120 Volt
DFWT-200 9100133	230	2800	12.2	50/60	CEE 7/7 16 Amp., 250 Volt

P/N 1020226 Rev. G 12/12