

Deluxe Food Warmer



DFW-150



DFW-250



DFWT-150



DFWT-250



DFWF-250

The Deluxe Food Cooker produces steam using plain tap water to quickly heat and reconstitute food items.

Simple push-button action delivers a fully adjustable impulse of steam. Because the amount of steam is consistent, it removes the guesswork and produces a uniform finished product from one operator to the next.

The Deluxe Food Cooker is manufactured from the finest materials available and assembled to Roundup's strict quality standards. All units are tested at the factory to ensure dependable trouble-free operation.

NOTE: Units with a direct water hookup require a water pressure regulator. The psi should be between 20 and 30.

Features:

- 0-99 minute timed steam cooking with instant warming button.
- Non-clogging.
- Uses plain tap water.
- Models available with either a self-contained water reservoir or direct water hookup.
- Safety steam release valve.

Deluxe Food Warmer

Dimensions

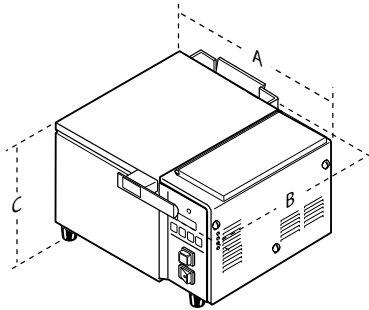

| Model & Mfg. No. | Width (A) | Depth (B) | Height (C) |
|------------------|---------------------|---------------------|--------------------|
| DFW-150 | 16 5/8" (422 mm) | 17 1/4" (438 mm) | 8 3/4" (222 mm) |
| DFWT-150 | 20" (508 mm) | 17 1/4" (438 mm) | 8 3/4" (222 mm) |
| DFW-250 | 16 5/8" (422 mm) | 17 1/4" (438 mm) | 8 1/4" (210 mm) |
| DFWT-250 | 20" (508 mm) | 17 1/4" (438 mm) | 8 3/4" (222 mm) |
| DFWF-250 | 26 7/8" (683 mm) | 17 1/4" (438 mm) | 9 3/8" (238 mm) |

Shipping Dimensions

| Model & Mfg. No. | Height | Width | Depth | Weight |
|------------------|-----------------|-----------------|-----------------|--------------------|
| DFW-150 | 12" (305 mm) | 21" (533 mm) | 21" (533 mm) | 42 lbs. (19 kg) |
| DFWT-150 | 12" (305 mm) | 21" (533 mm) | 21" (533 mm) | 50 lbs. (23 kg) |
| DFW-250 | 12" (305 mm) | 21" (533 mm) | 21" (533 mm) | 45 lbs. (20 kg) |
| DFWT-250 | 12" (305 mm) | 21" (533 mm) | 21" (533 mm) | 75 lbs. (34 kg) |
| DFWF-250 | 14" (356 mm) | 21" (533 mm) | 33" (838 mm) | 75 lbs. (34 kg) |

Electrical Ratings and Plug Configuration

| Model & Mfg. No. | Volts | Watts | Amps | Hertz | Plug Description |
|------------------|-------|-------|------|-------|------------------|
|------------------|-------|-------|------|-------|------------------|

With Self-Contained Water Tank

| | | | | | |
|---------------------|-----|------|------|-------|---------------------------------|
| DFW-150 9100104 | 120 | 1800 | 15 | 50/60 | NEMA 5-15P 15 Amp., 120 Volt |
| DFW-150 9100105 | 120 | 1500 | 12.5 | 50/60 | NEMA 5-15P 15 Amp., 120 Volt |
| DFW-150 9100106 | 230 | 2800 | 12.2 | 50/60 | CEE 7/7 16 Amp., 250 Volt |
| DFWT-150 9100124 | 120 | 1800 | 15 | 50/60 | NEMA 5-15P 15 Amp., 120 Volt |
| DFWT-150 9100126 | 230 | 2800 | 12.2 | 50/60 | CEE 7/7 16 Amp., 250 Volt |

With Direct Water Hookup

| | | | | | |
|---------------------|-----|------|------|-------|---------------------------------|
| DFW-250 9100114 | 120 | 1800 | 15 | 50/60 | NEMA 5-15P 15 Amp., 120 Volt |
| DFW-250 9100116 | 230 | 2800 | 12.2 | 50/60 | CEE 7/7 16 Amp., 250 Volt |
| DFWT-250 9100134 | 120 | 1800 | 15 | 50/60 | NEMA 5-15P 15 Amp., 120 Volt |
| DFWT-250 9100136 | 230 | 2800 | 12.2 | 50/60 | CEE 7/7 16 Amp., 250 Volt |
| DFWF-250 9100146 | 208 | 3300 | 15.9 | 50/60 | NEMA 6-20P 20 Amp., 250 Volt |

Capacities

| | |
|-------------|--|
| DFW Series | 2 7/8" (73 mm) deep 1/2-size steam table pan |
| DFWT Series | 2 7/8" (73 mm) deep 2/3-size steam table pan |
| DFWF Series | 4" (102 mm) deep full-size steam table pan |



A.J. Antunes & Co.
We exist to make our customers successful.

A.J. Antunes & Co.
Headquarters/Manufacturing
Carol Stream, Illinois 60188 USA
Phone: (630) 784-1000
Toll Free: (800) 253-2991
Fax: (630) 784-1650

Antunes Equipment
Manufacturing (Suzhou) Ltd.,
Suzhou, Jiangsu, China 215011
Phone: 86-512-6841-3637
Toll Free: 400-0-7878-22
Fax: 86-512-6841-3907

P/N 1020236 Rev. F 02/12