

RT Radiant Toaster



RT-2

Introducing the RT-2 Radiant Toaster. It is the smallest of our radiant toasters and features two toasting lanes for a high toasting capacity without wasting valuable counterspace. This unit has a front load and a front return with an integrated holding zone.

The RT-2 utilizes an advanced smart controller that senses product and automatically adjusts the toast time based on volume and operator settings. This ensures the bagels and muffins always have a consistent, high-quality toast, even during barrel runs.

Features

- Smart controller senses product and automatically adjusts toast time.
- Consistent toast quality for bagels and muffins even during barrel runs.
- Digital controller allows users to easily adjust toast quality.
- Integrated holding zone.
- Easy to clean.
- Front load and front return.



RT Radiant Toaster

Dimensions

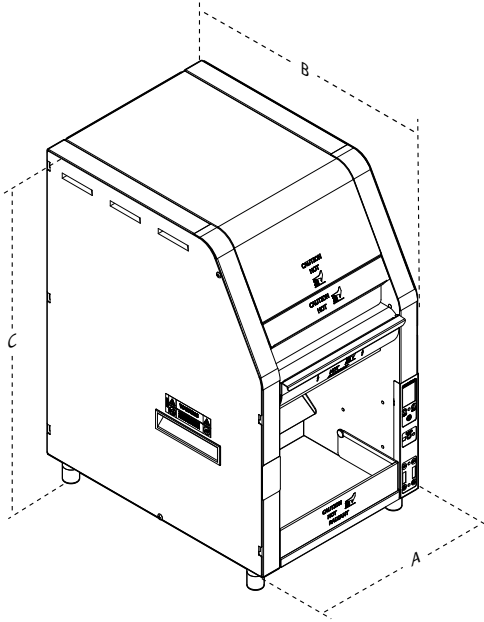

Electrical Ratings and Plug Configuration

Model & Mfg. No.	Volts	Phase	Watts	Amps	Hertz	Plug Description
RT-2 9210908	208	1	5000	24	50/60	NEMA L6-30P 250 Volt, 30 Amp. Twist Lock

Specifications

Temperature Control: Solid State with Display

Power Cord: Six-foot grounded power cord supplied

Model & Mfg. No.	Width (A)	Depth (B)	Height (C)
RT-2 9210908	13" (330 mm)	19" (481 mm)	23 1/2" (597 mm)

P/N 1020460 Rev. A 10/15