

Trough Collector



Job: _____ Item No.: _____

Model S419



A Trough Conveying and Food Waste Collecting System

Widely accepted in areas that restrict the use of food waste disposers.

Recirculated Water used for scrapping typically reduces water and sewer costs dramatically. The Trough Collector consumes only 2 gallons of new water per minute.

Trough Water Velocity with the Trough Collector is 70 gallons per minute. This velocity swiftly propels food waste down the trough and into the Collector with no additional hand movement, leaving both hands free for high-volume scrapping. The Trough Collector will let you keep up with large conveyor or flight dishmachines.

Design Flexibility is offered by the Collector as troughs can turn one or more corners and have wider troughs for soaking problem dishes.

Wider and Longer Troughs can be designed because of the Collectors high water velocity which allows you to soak problem dishes or add gusher heads to pre-rinse compartmental trays.

TYPICAL INSTALLATIONS

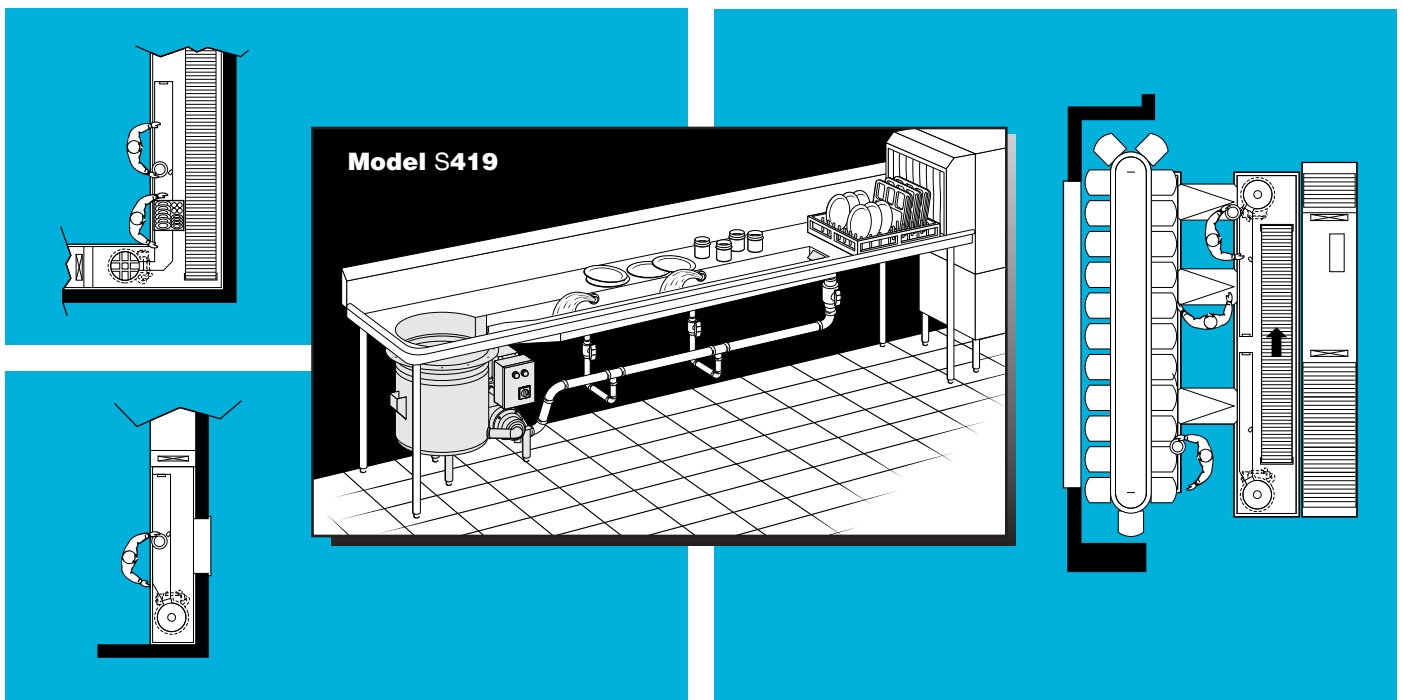



Trough Collector Model S419

Trough Collector Legend

- A** Tank drain 2" NPT
- B** 1/2" conduit knockout electrical connection
- C** Hot/cold shutoff valves 1/2" NPT
- D** Removable Top

DETAIL "C" RECIRCULATION PLUMBING

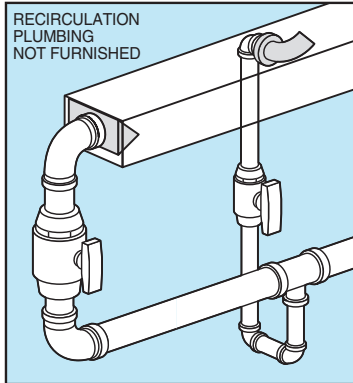

Note: Add 6" from back of trough to wall for recirculation piping.

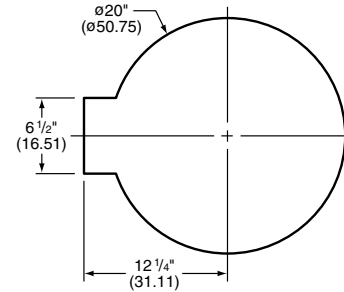
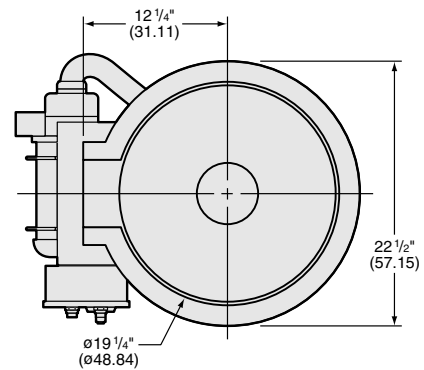
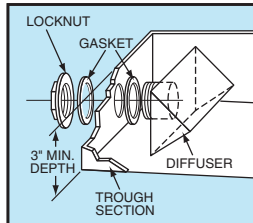

TABLE CUTOUT DETAIL



TOP VIEW

DETAIL "A" - WATER DIFFUSER



DETAIL "B" - TROUGH CONNECTION FLANGE

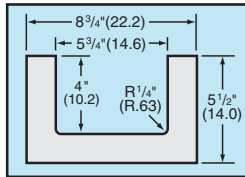

WATER DIFFUSER FURNISHED. 2" DIA. HOLE REQUIRED IN BACK OF TROUGH. (SEE DETAIL "A")

3/4" PIPE AND VALVE (SEE DETAIL "C")

TROUGH CONNECTION (SEE DETAIL "B")

SCRAP BASKET DIMENSIONS
18 9/16" Dia. x 13 1/4" High
(47.2 Dia. x (33.7) High)

ONE BASKET PROVIDED WITH UNIT
Additional basket recommended at additional cost

22" (55.88) MINIMUM CLEARANCE OVERHEAD FOR BASKET REMOVAL

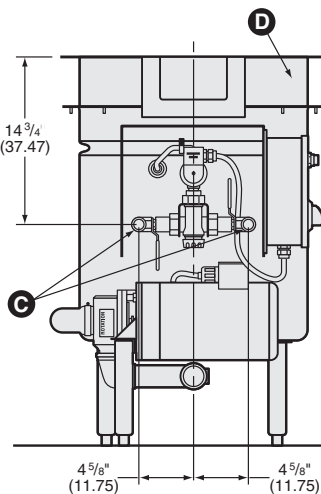

LEFT SIDE VIEW

WE SUGGEST THE USE OF RUBBER GUSHER HEADS ALONG THE TROUGH FOR SCRAPPING AND PRE-FLUSHING. (OPTIONAL AT ADDITIONAL COST)

1 1/2" PLUMBING FITTINGS AND VALVE (SEE DETAIL "C")

FABRICATED TROUGH (NOT FURNISHED), MUST HAVE MATCHING FLANGE TO ATTACH TO MODEL S419. (SEE DETAIL "B")

CONTROL PANEL CAN BE MOUNTED ON LEFT OR RIGHT.

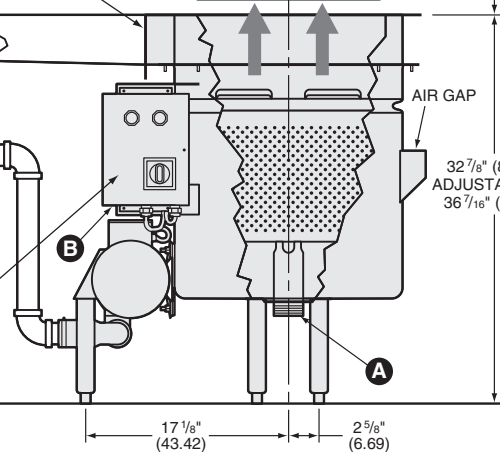

FRONT VIEW



Trough Collector Model S419

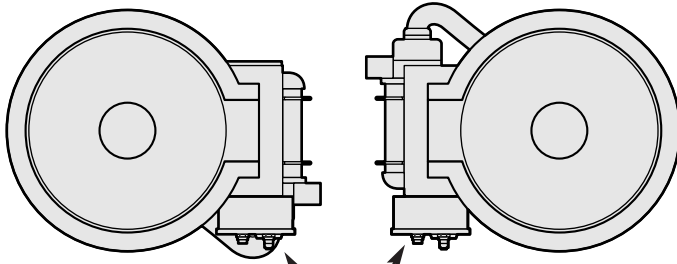

MSS-LD Control

The MSS-LD control can be mounted on either side of the Collector with existing fasteners, mounting holes and wiring for left or right hand operation.

#980104 MSS-LD Mounting Bracket

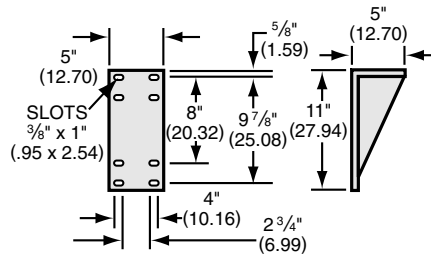

The control can be mounted remotely using optional mounting bracket.

Note: additional field wiring is necessary.

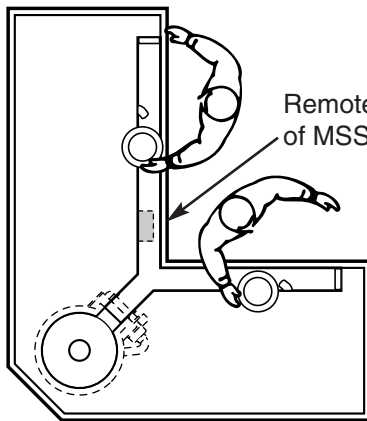

Remote Mounting of MSS-LD Control

Upon request, the Collector top may be shipped separately to an alternate location for fabrication.

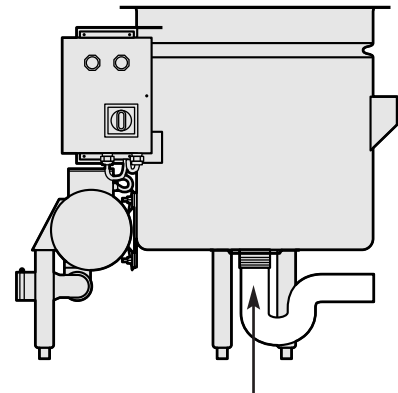

2" TANK DRAIN
(Piping not furnished)

ALL CONNECTIONS ARE TO BE MADE BY QUALIFIED PERSONNEL WHO WILL OBSERVE ALL LOCAL AND NATIONAL CODES.

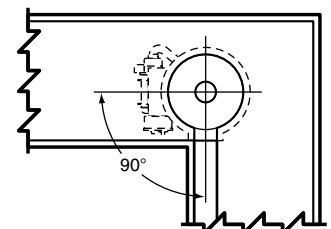
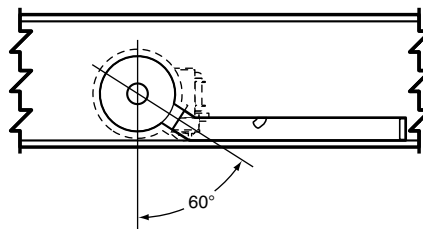

The Trough Collector top can be rotated in 15 degree increments to ease common installations as well as improve design flexibility without the need of costly tank modifications.

NOTE: Dimensions in parenthesis are in centimeters

Salvajor Trough Collector

MODEL S419

S P E C I F I C A T I O N S

CONSTRUCTION

- Tank - 2 Piece Stainless Steel
- Adjustable Legs - Stainless Steel
- Control Panel - Stainless Steel
- Salvage Basin - High Impact Polymer
- Scrap Basket - High Impact Polymer

ELECTRICAL

- Pre-wired NEMA 4 Control Panel
- Watertight Conduit/Fittings
- Separate Component Grounding
- Thermally Protected Motor
- Safety Line Disconnect

PLUMBING

- Corrosion Resistant Components
- Automatic Water Blender
- Solenoid Valve
- Unions
- Check Valves
- Incoming Water Valves
- Non-clogging Pump Design
- Backflow Prevention Device

ACCESSORIES

- Remote Start-Stop
- Remote Mounting Bracket
- Correctional Package
- MSS-LD Mounting Bracket
- Additional Scrap Basket

VOLTAGES AVAILABLE

(SPECIFY EXACT OPERATING VOLTAGE)

- 115V 208V 230V, 60 Cycle, 1 Phase
- 208V 230V 460V, 60 Cycle, 3 Phase

Pump Motor **3/4 HP**

FULL LOAD AMPS

(SPECIFY EXACT OPERATING VOLTAGE)

1 PHASE			3 PHASE		
115V	208V	230V	208V	230V	460V
11	5.5	5.5	3.2	3	1.5

UTILITIES REQUIRED

1. Electric service
2. 3/4" hot and cold water supply and reduce to 1/2" at connection.
3. 2" tank drain.

(Specifications subject to change without notice.)

SAMPLE SPECIFICATIONS

Unit shall be a Salvajor Trough Collector, a complete scrapping, pre-flushing and food waste collecting system with recirculating water as manufactured by Salvajor.

Model S419, ___ Volts, 60Hz, ___ Phase.

Furnished with a pre-wired control panel and stainless steel NEMA 4 watertight enclosure.



The Salvajor Company 4530 East 75th Terrace Kansas City, Missouri 64132-2081, USA

1-800-SALVAJOR

(816) 363-1030

FAX: 1-800-832-9373

www.salvajor.com

Email: sales@salvajor.com

service@salvajor.com

Manufacturers of Commercial Food Waste Disposing Systems since 1944