



Job: _____

Item No. _____

DESIGNED FOR HIGHER VOLUME APPLICATIONS

Five – 16 oz. Servings per Minute – 20 Quart Capacity

GREAT FOR RESTAURANTS, BUFFETS, & ICE CREAM SHOPS

The **SaniServ** Model 614SAS Shake Freezer provides up to four flavors of uniform, smooth, high profit shakes! The 614SAS automatically mixes each shake uniformly to insure a perfect milk shake in the flavor desired! Owners and operators will appreciate the machine's quick recovery time and ability to provide everyone's favorite flavor quickly even during peak operating periods! The 614SAS can satisfy everyone with their favorite flavor every time!

SPACE SAVING

Compact Floor Model Design - SaniServ model 614SAS provides a high volume of milk shake in the traditional floor model design. Operators can turn that valuable floor space into a high profit center by providing consistent high quality shakes customers demand.

EASY CLEANING AND OPERATION

Fewer Parts = Simplified Cleaning – SaniServ equipment is designed and built with the fewest parts to be disassembled, cleaned and sanitized than any other machine in the industry.

HIGH RETURN ON INVESTMENT

Increased Profits – SaniServ machines combine efficiency with consistent product quality and fast, quiet operation while insuring customer satisfaction with high profit ice cream or yogurt products.

QUALITY DESIGN

Durability – SaniServ machines are built to achieve long and dependable life through simplicity of design. Every machine is shipped standard with a stainless steel exterior, durable steel interior frame construction, heavy-duty components and consistency systems.

Model 614SAS

Floor Model
Select-A-Shake Machine



Made in USA

We reserve the right to change specifications and product designs without notice. Such revisions do not entitle the buyer to corresponding changes, improvements, additions or replacements for previously purchased equipment.

451 E. County Line Rd. • P.O. Box 1089 • Mooresville, IN 46158
Toll Free 800-733-8073 • Local 317-831-7030 • Fax 317-831-7036
www.saniserv.com

VER: 1-13

MODEL 614SAS

Floor Model Shake Freezer

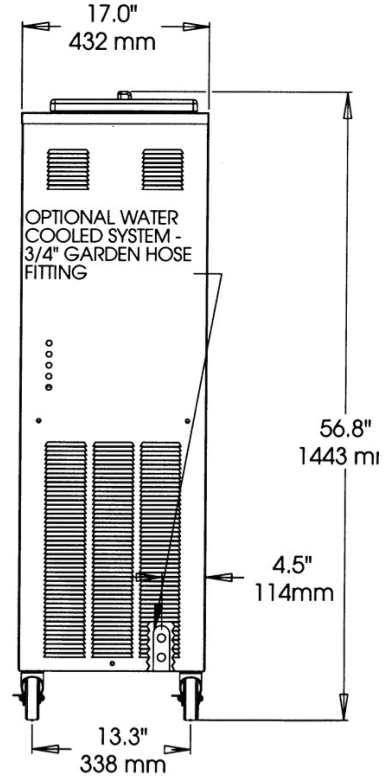
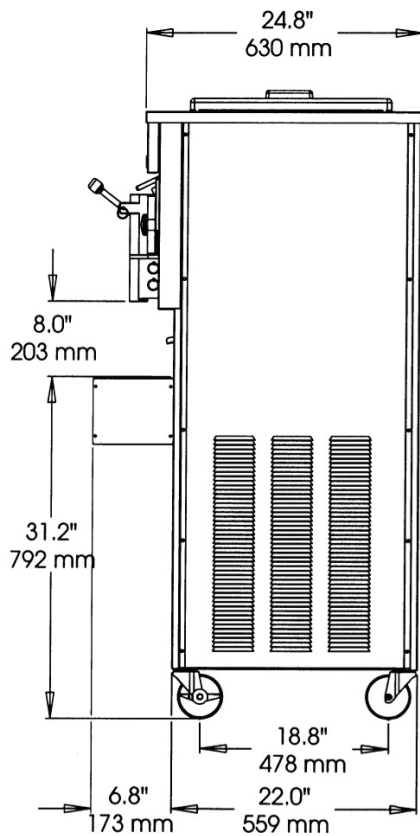
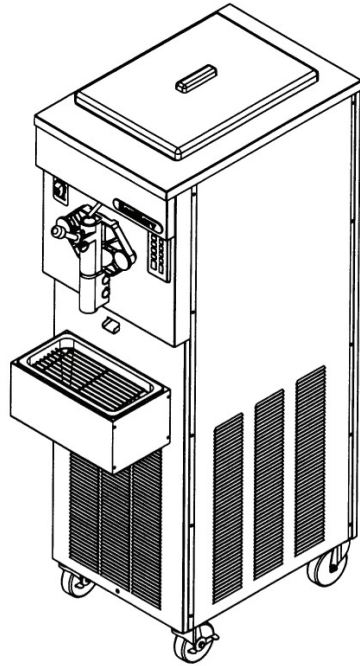

Minimum Wall Clearance
Both Sides and Back -
6 inches (152 mm)

ELECTRICAL				WIDTH	HEIGHT	DEPTH	WEIGHT	VOLUME
VOLTS	Hz	Ph.	Amps	INCHES (MM)	INCHES (MM)	INCHES (MM)	LBS. (Kg)	CU FT. (cu. m.)
208-230	60	1	25	17 (432)	56.8 (1443)	24.8 (630)	352 (153)	
208-230	60	3	20					
Shipping Specifications				24.5 (622)	58.1 (1476)	40.5 (1028)	420 (191)	32.5 (.92)

Specifications:

Cooling System:
Air or Water

Dasher and Compressor Motors:

1/2 HP Dasher
2 HP Compressor

Refrigerant Type:

R404A

Listings:

UL, cUL, NSF

This unit requires CO2 connection and a water line connection. The unit comes with 10' syrup line, (3) three gallon canisters, and one regulator.

Features:

Evaporator and Mix Reservoir Capacity:
20 Quarts (18.9 liters)

Dasher:

Heavy-Duty Stainless Steel with low friction scraper blades.

Controls:

Automatic consistency controls for improved consistency.

Tamper Proof Automatic Visual Mix Out System

Warranty:

Parts 1 year
Compressor 5 years
Evaporator 5 years

Options:

Tune Up Kit
Parts Tray
Syrup Rail
Drink Spinner
Water Cooled - 3/4" Garden Hose Fitting
Wash Out Kit - 3/8" Flare Fitting
Export Voltages