



Job: \_\_\_\_\_

Item No. \_\_\_\_\_

## DESIGNED FOR HIGH VOLUME APPLICATIONS

**Seven – 4 oz. Servings per Minute - 20 Quart Capacity per side**

### INCREASE YOUR PROFITS

Combine efficiency with consistent, high overrun, high quality product and fast, quiet operation to insure customer satisfaction with high profit ice cream products.

### DIAL IN YOUR OVERRUN

You can set the percentage of overrun to maximize your yield, taste, mouth appeal and profit. The 924 delivers the same overrun from the start of the day till the end.

### FAST SERVICE

Just pull the spigot handle to dispense the product. The pressurized 924 delivers product at a fast, even pace.

### HIGH VOLUME OF PRODUCT

Up to seven 4 oz. servings per side. Fast recovery insures availability of product for high volume operations, even during peak periods. Ideal for Quick Serve Restaurants, Full Service Operations, C-stores, Concessionaires, and Stadiums.

### REFRIGERATED CABINET

Is designed to hold 10 gallons of fresh soft serve mix in the integral cabinet and to maintain the product in the reservoir at a uniform temperature that exceeds even the most stringent standards.

### STATE OF THE ART MIX DELIVERY SYSTEM

The unique peristaltic pump and air mix delivery system are front mounted for easy access, cleaning and adjustment.

### STATE OF THE ART MIX OUT SYSTEM

Tamper proof system alerts the operator when product in the reservoir is low and needs to be replenished.

### FAST, EASY CLEANING

SaniServ equipment is design to be easily cleaned and sanitized, with the fewest parts possible for rapid assembly and disassembly.

### INVEST IN EQUIPMENT BUILT TO LAST

SaniServ soft serve machines achieve long and dependable life through simplicity of design, durable steel frame construction, heavy-duty components and drive system. Shipped standard with stainless steel exterior.

# Model 924

Floor Model  
**Pressurized, Refrigerated  
Cabinet  
Soft Serve Ice Cream Machine**



Made in USA

We reserve the right to change specifications and product designs without notice. Such revisions do not entitle the buyer to corresponding changes, improvements, additions or replacements for previously purchased equipment.

451 E. County Line Rd. • P.O. Box 1089 • Mooresville, IN 46158  
Toll Free 800-733-8073 • Local 317-831-7030 • Fax 317-831-7036  
[www.saniserv.com](http://www.saniserv.com)

# MODEL 924

## Floor Model High Production Pressurized Soft Serve Ice Cream Machine

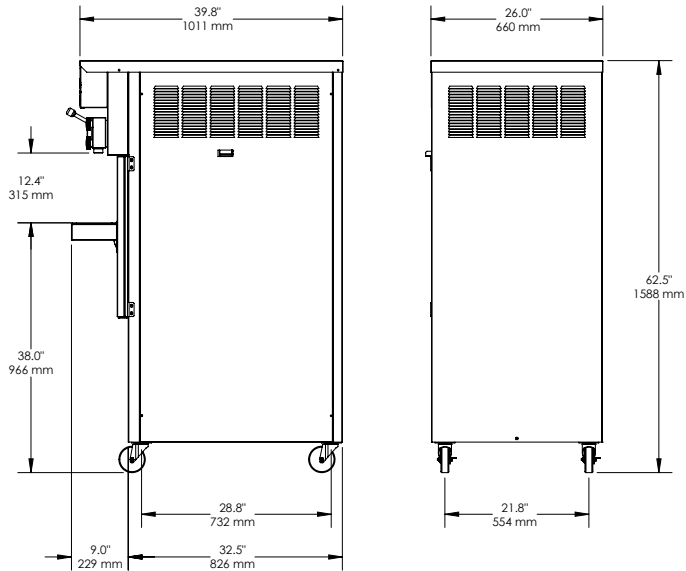
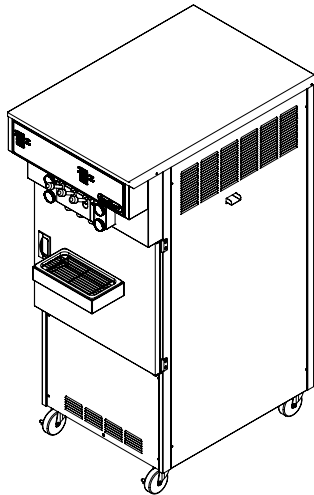

Minimum Wall Clearance  
Both Sides and Back -  
6 inches (152 mm)

ELECTRICAL				WIDTH	HEIGHT	DEPTH	WEIGHT	VOLUME
VOLTS	Hz	Ph.	Amps	INCHES (MM)	INCHES (MM)	INCHES (MM)	LBS. (Kg)	CU FT. (cu. m.)
208-230	60	1	35 *	26 (660)	62.5 (1588)	39.8 (1011)	580 (263)	
208-230	60	3	25 *	26 (660)	62.5 (1588)	39.8 (1011)	580 (263)	
Shipping Specifications				36 (914)	65 (1651)	40 (1016)	650 (295)	54.8 (1.53)

### Specifications:

\* *Two separate circuits required*

#### Cooling System:

Air or Water cooled condensers

#### Dasher and Compressor Motors:

2 - 1 HP Dasher  
2 - 2 HP Freezing Cylinder  
Compressor  
1/5 HP Refrigerated Cabinet  
Compressors

#### Refrigerant Type:

R404A - Freezing cylinder  
R404A - Refrigerated Cabinet

#### Listings:

UL, cUL, NSF

### Features:

#### Evaporator Capacity:

2 - 3.8 quart (3.6 liters)  
2 - 20 Quarts reservoirs in cabinet

#### Dasher:

Heavy-Duty Stainless Steel with low friction scraper blades.

#### Controls:

**AccuFreeze** with touch pad controls for freezing cylinder, refrigerated cabinet and pump.

#### Audio/Visual Mix Out System and pump alarm.

### Warranty:

Parts 1 year  
Compressor 5 years  
Evaporator 5 years

### Options:

Tune Up Kit  
Export Voltages

451 E. County Line Rd. • P.O. Box 1089 • Mooresville, IN 46158  
Toll Free 800-733-8073 • Local 317-831-7030 • Fax 317-831-7036

www.saniserv.com