

# FOOD WARMERS: MERCHANDISERS

## BUTTER SERVER, SUPREME™

Model BSW-SS



 **BSW-SS 86540**



ALSO AVAILABLE FOR EXPORT

### TWO YEAR WARRANTY

Server Products equipment is backed by a two-year limited warranty against defects in materials and workmanship. For a copy of our complete warranty statement, please refer to [server-products.com](http://server-products.com).

### BID DESCRIPTION

The Supreme™ butter warmer BSW-SS is designed with pump and spout warmer opposite the instrument panel side and dispenses directly from a supplied 3 quart (2.8 L) stainless steel jar. A brushed (#4) stainless steel body with black thermoset plastic bottom and top house its stainless steel pump which features a cast valve body with captured balls to prevent loss. Portions are preset to yield ¼ ounce (7 mL) per stroke and can be increased up to 1 ounce (30 mL). Unit also includes a magnetic Butter merchandising sign (86791).

An adjustable, precalibrated thermostat turns the 500 watt heating element off and on as needed. The base also features a water fill line to eliminate overflow accidents and a "Power On" light. Power is controlled by an On/Off rocker switch.

### STANDARD FEATURES

- NSF- Listed as a rethermalization unit
- Pump design with captured valve balls to prevent loss
- Preset to yield a ¼ ounce (7 mL) per stroke, can be increased up to 1 ounce (30 mL)
- Adjustable, precalibrated thermostat for accurate heat control
- Temperature marks on knob with protective knob guard
- Water fill line eliminates overflow accidents
- Includes magnetic Butter merchandising sign

### ACCESSORY ITEMS

- 3 qt (2.8 L) Stainless Steel Jar 94009
- Stainless Steel Jar, Storage Lid 94008

# FOOD WARMERS: MERCHANDISERS

## BUTTER SERVER, SUPREME™

Model BSW-SS

### BUTTER SERVER SUPREME™

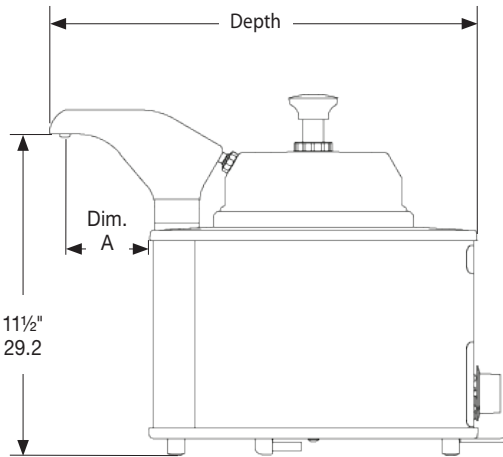
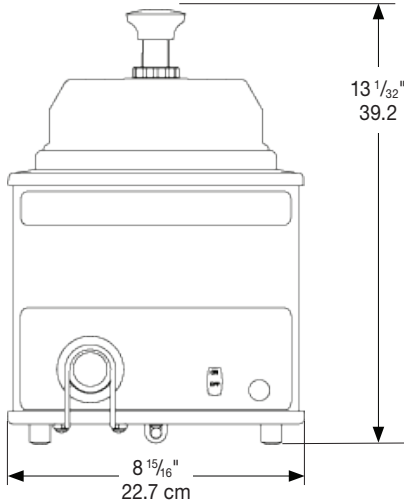

### SPECIFICATIONS

Construction	Stainless steel base with black thermoset plastic bottom and top. Pump features a rugged cast valve body and welded construction.			
Certifications	NSF, NSF Rethermalization, C UL US NSF listing for rethermalization ensures food is quickly heated to a safe temperature before bacteria has an opportunity to grow. 			
Capacity	Jar holds 3 quarts (2.8 L) — not included.			
Dimensions	<u>Height</u>	<u>Width</u>	<u>Depth</u>	<u>Dim A</u>
	15 <sup>7</sup> / <sub>16</sub> "	8 <sup>15</sup> / <sub>16</sub> "	15 <sup>1</sup> / <sub>2</sub> "	3 <sup>1</sup> / <sub>16</sub> "
	39.2 cm	22.7 cm	39.4 cm	7.8 cm
Electrical	120V, 60Hz, 517W, 4.3A, 72 in (183 cm) cord set NEMA 5-15P, 15A, 125V PLUG			
Weight	16 lb (7.3 kg)			

FOB RICHFIELD, WISCONSIN 53076

### CAD LIBRARY

Individual CAD images can be downloaded from our website. We are also a member of The KCL CADalog with more than 100 other manufacturers. Our complete collection of CAD files can be purchased through Kochman Consultants, Ltd. at [kclcad.com](http://kclcad.com).