



# TOPPING STATIONS {WHIPPED TOPPING SOLUTIONS} TOPPING TRIGGER™

Model TOPT

Date:

Project:

Quantity:

Item Number:



**TOPT 87060**



**TOPT 87079**

## Bid Description

Server Products, together with Rich Products Corporation, the leader in whipped topping, have collaborated to bring you convenient dispensing options which meet your operational needs.

The Topping Trigger™ is a hand held dispenser that delivers a controlled dollop of specified Rich's® Whipped Topping. Compatible packaging is a **NEW** patent pending cylindrical design. See back for listing. Each squeeze of the trigger dispenses a full dollop with three settings to reduce dollop portion. The system is NSF listed and designed with safety in mind, no compressed gas required.

## Standard Features

- Accommodates new specified Rich's® Whipped Topping
- Sealed system virtually eliminates cross contamination risk
- Design permits single-handed dispensing
- Flexible product package maximizes evacuation
- Portion options: (1) Full & (3) reduced portions
- Recyclable packaging eliminates solid waste issues & nitrous oxide (N<sub>2</sub>O) concerns
- Free standing & portable — easily fits into any operation
- Dishwasher safe for fast & easy clean-up

## Two Year Warranty

Server Products equipment is backed by a two-year limited warranty against defects in materials and workmanship. For our complete warranty statement, please refer to [server-products.com](http://server-products.com).



Patent Pending



**Model TOPT**

**TOPPING STATIONS {WHIPPED TOPPING SOLUTIONS}**  
**TOPPING TRIGGER™**

**Topping Trigger™**

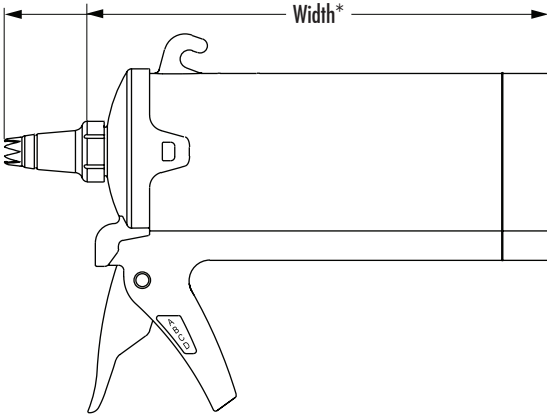

**Specifications**

<b>Model</b>	<b>TOPT 87060 &amp; 87079-OT</b>			
Construction	Durable ABS/Polycarbonate blend with stainless steel drive mechanism.			
Capacity	Up to 11.5 oz (326 g) Rich's® Whipped Topping			
Dimensions	<u>Height</u>	<u>Width</u>	<u>Width*</u>	<u>Depth</u>
	in 9 1/16	13 1/16	11 7/8	4
	cm 23	33.2	30.2	10.4
	Width* is without extender tip installed.			
Weight	3 lb (1.4 kg)			

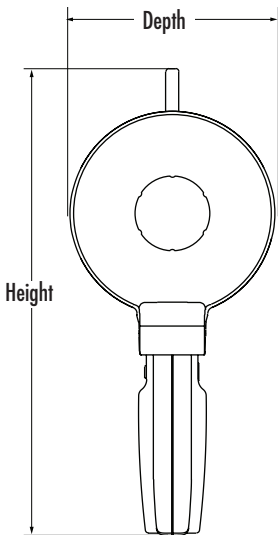

**RICH'S® Pre-Whipped Topping Product**

Contact your Rich's® representative, to purchase Whipped Topping product for the Rich's® Whipped Topping Dispensing System™.

**NOTE: This is a NEW cylindrical bag design.**

PC 05543 On Top® Whipped Topping (16) 11.5 oz (326 g)

Be sure to refrigerate your Rich's® On Top® Whipped Topping, when not in use.

Topping Trigger™ is a trademark owned by Rich Products Corporation. Rich's® and On Top® are registered trademarks of Rich Products Corporation.

FOB Richfield, Wisconsin 53076

**CAD Library**

Individual CAD images can be downloaded from our website. We are also a member of The KCL CADalog with more than 100 other manufacturers. Our complete collection of CAD files can be purchased through Kochman Consultants, Ltd. at [kclcad.com](http://kclcad.com).

