

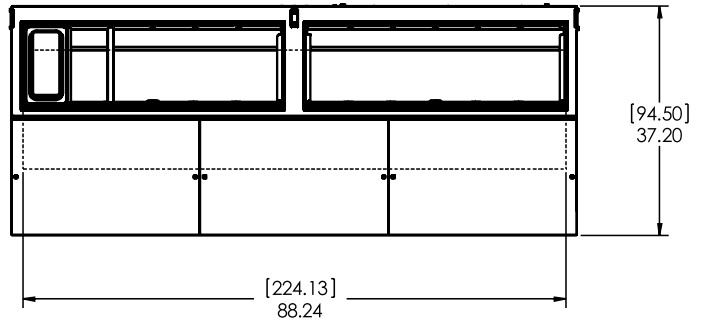

# Refrigerated Prep Table

MODEL SKPZ92/C2

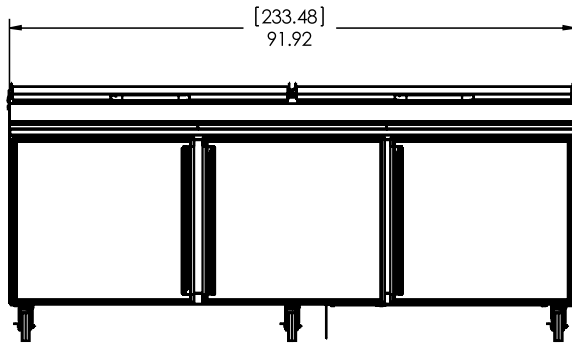
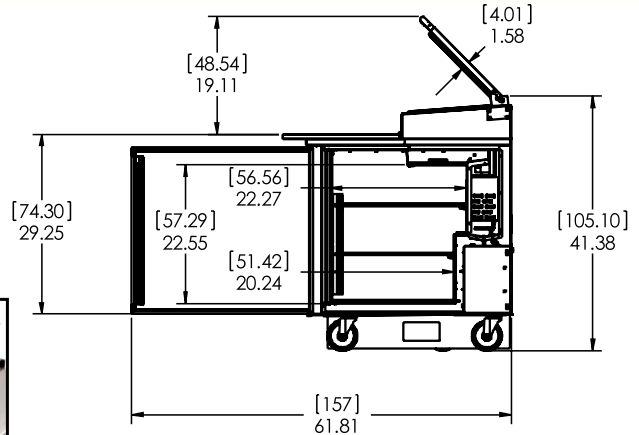

MODEL	LENGTH	DEPTH	HEIGHT	COMPRESSOR	AMPS	WEIGHT
SKPZ92/C2	92"	37.20"	41.38"	3/4 HP	13	680 lbs.

- EXTERIOR** Stainless steel, galvanized back.
- INTERIOR** Aluminum. Coved corners and finished edges for ease of cleaning.
- INSULATION** Environmentally friendly foamed-in-place polyurethane for maximum strength and durability.
- REFRIGERATION** CFC-free, R404a refrigerant, hermetically sealed, high efficiency, self contained refrigeration system.
- DOORS** Polyurethane insulation, heavy duty extruded aluminum frame, stainless steel exterior door panel, and extra heavy duty magnetic "Thermo Rubber" door gasket combine to make the toughest, longest lasting door in the industry.
- LISTINGS** ETL Safety (U.S. and Canada), ETL Sanitation.
- WARRANTY** One year parts and labor. Five year warranty on compressor.



1600 Xenium Lane North  
 Minneapolis, MN 55441-3787  
 Phone (763) 923-2441  
 Fax (763) 553-1209  
[www.silverking.com](http://www.silverking.com)



Specifications subject to change without notice.

7/2013  
 © Silver King 2013  
 Printed in U.S.A.