



ELECTRIC COUNTER PAN STEAMER MANUAL FILL, MANUAL DRAIN



Model shown is an EZ18-3

SPECIFICATIONS:

Provide Southbend model **EZ18-3 (3 pan)** or **EZ18-5 (5 pan)** countertop, boiler free convection steamer, c-CSA-us and NSF certified. Unit shall be connectionless, no plumbing required.

Unit shall be constructed of satin finish 304 stainless steel with a one piece welded 316 stainless steel cooking chamber with coved corners. The door shall have a removable inner liner of stainless steel with full perimeter gasket seal, an outer liner of one-piece all welded stainless steel, and a positive lock and seal mechanism with spring release. The steamer shall have removable stainless steel pan supports and steam diffuser plate.

The control housing shall be constructed of stainless steel with a full access removable panel. The controls shall include an illuminated timed cooking/off/constant steam switch, a ready indicator light, cooking indicator light, 60 minute electric timer with audible alarm that signals the end of the cook cycle and a low water indicator light with audible alarm. A door interlock switch shall interrupt steam generation when the door is open and shall be reactivated when the door is closed. Provide options and accessories as indicated.

NOTE: DRAIN PAN PROVIDED BY OTHERS.

MODEL	COMPARTMENT PAN CAPACITY			
	PAN DEPTH			
	1"	2-1/2"	4"	6"
EZ18-3	6	3	2	1
EZ18-5	10	5	3	2

OPERATION SHALL BE BY:

Electrically heated, boiler free steam generation rated at:

- 9.0 kw for Model EZ18-3
- 15.0 kw for Model EZ18-5

The steam boiler shall be equipped for operation on:

- 208 VAC, 3 Phase, 50/60 Hz. *
- 240 VAC, 3 Phase, 50/60 Hz. *

* UNIT SHALL BE FIELD CONVERTIBLE TO SINGLE PHASE AND ALSO CONFIGURABLE TO 2/3 RATING.

- 6.0 kw for Model EZ18-3
- 10.0 kw for Model EZ18-5

STANDARD FEATURES:

- 304 stainless steel exterior.
- 316 stainless steel cooking chamber with coved corners.
- Heavy gauge stainless steel door with full perimeter gasket.
- Positive lock and seal mechanism with spring release door.
- Illuminated timed/off/constant steam power switch.
- Ready indicator light.
- Cooking indicator light.
- Add water indicator light with audible alarm.
- 60 minute electromechanical timer with end of cycle audible alarm.
- 4" adjustable legs
- Removable stainless steel pan supports.
- Removable steam diffuser plate helps prevent objects from falling into water reservoir.
- Selectable timed or constant steam cooking mode.
- Electromechanical controls.

OPTIONS AND ACCESSORIES:

- 220 VAC, 3 Phase, 50/60 Hz.
- 380 VAC, 3 phase, 50/60 Hz.
- 415 VAC, 3 phase, 50/60 Hz.
- 480 VAC, 3 phase, 50/60 Hz.
- 600 VAC, 3 phase, 50/60 Hz. (EZ18-3 only)
- 380/220 VAC, 3 Phase, 50/60 Hz 4 wire.
- 415/240 VAC, 3 Phase, 50/60 Hz 4 wire.
- Correctional package.
- 120 minute timer
- Drain hose kit (includes 5' hose with fitting)
- 28" high single unit stand and double unit stacking stands available (Contact factory for details)

Job _____
Item# _____



Models: EZ18-3 EZ18-5

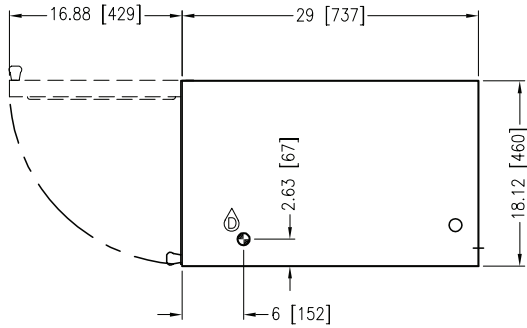

SERVICE CONNECTIONS
 ⚡ – ELECTRICAL CONNECTION: Ø 1 1/8" (29 mm) hole for electrical connection. Rating to be specified on data plate.
 Ⓛ – DRAIN: 1/2" NPT

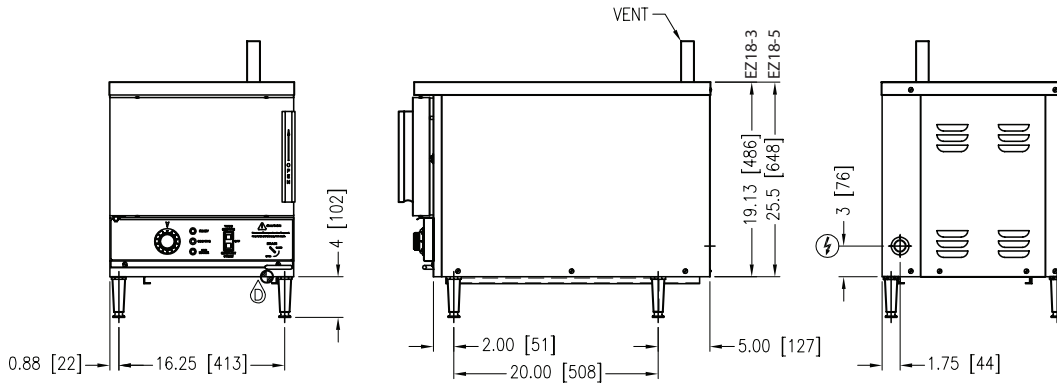

ELECTRICAL CHARACTERISTICS

MODEL	kW	AMPS/PHASE									
		208V		220V		240V		380V	415V	480 V	600V
		1 PH	3 PH	1 PH	3 PH	1 PH	3 PH	3 PH	3 PH	3 PH	3 PH
EZ18-3	9	43.3	25.0	40.9	23.6	37.5	21.7	13.7	12.5	10.8	8.7
	6	28.9	N/A	27.3	N/A	25.0	N/A	N/A	N/A	N/A	N/A
EZ18-5	15	72.1	41.6	68.2	39.4	62.5	36.0	22.8	20.9	18.0	14.4
	10	48.1	N/A	45.5	N/A	41.7	N/A	N/A	N/A	N/A	N/A

PAN CAPACITIES

MODEL	PAN DEPTH	INCHES MM	1"	2.5"	4"	6"	SHIPPING WEIGHT	MINIMUM CLEARANCE	
			25	64	102	152		SIDES	0
EZ18-3	Total Quantity of Pans	6	6	3	2	1	161 lbs. [73 kg]	SIDES	0
EZ18-5		10	10	5	3	2		183 lbs. [83 kg]	BACK

WATER QUALITY STATEMENT

Water quality is the major factor affecting the performance of your appliance. If you are unsure of water quality, consult a local water treatment specialist and have the water analyzed. Your water supply must be within these general guidelines:

- Total dissolved solidsLess than 60 PPM
- Total alkalinityLess than 20 PPM
- Silica.....Less than 13 PPM
- ChlorineLess than 1.5 PPM
- pH Factor7.0 - 8.5

Water which fails to meet these standards should be treated by installation of water conditioner.

FAILURE OR MALFUNCTION OF THIS APPLIANCE DUE TO POOR WATER QUALITY IS NOT COVERED UNDER WARRANTY.

**INTENDED FOR COMMERCIAL USE ONLY.
NOT FOR HOUSEHOLD USE.**



1100 Old Honeycutt Road, Fuquay-Varina, NC 27526
(919) 762-1000 www.southbendnc.com