

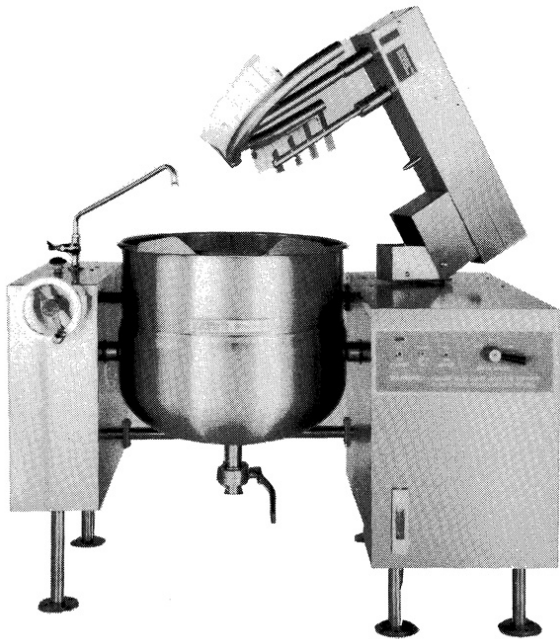

# DIRECT STEAM LEG-MOUNTED TILTING MIXER KETTLE

Job \_\_\_\_\_  
Item# \_\_\_\_\_



MODEL	CAPACITY	
KDMTL-40	40 Gallon	152 Liter
KDMTL-60	60 Gallon	227 Liter
KDMTL-80	80 Gallon	303 Liter
KDMTL-100	100 Gallon	380 Liter

### OPERATION SHALL BE BY:

Direct steam. Hydraulic power supply is standard either:

- 208 Volts, 3 Phase, 60 Hz
- 240 Volts, 3 Phase, 60 Hz

### OPTIONAL ITEMS AT EXTRA COST:

- Swing faucet on left console
- 3" manual butterfly valve
- 2" manual butterfly valve
- 316 stainless steel liner for high acid content products
- 480 VAC, 60 Hz, 3 Phase (for motor)
- Quick chill system
- Steam control assembly (STA-)
- High pressure operation (HP-50)

### SPECIFICATIONS:

Shall be a Southbend Model \_\_\_\_\_, direct steam tilting kettle operating at a maximum of 35 psi. Construction shall be welded stainless steel type 304 satin finish. A double wall kettle interior shall form a steam jacket around the lower 2/3 of the kettle. The bottom of the kettle shall be of hemispheric design for maximum heat transfer. The tubular legs shall be constructed of stainless steel pipe fitted with four hole, adjustable, flanged feet for securing to the floor. A sealed stainless steel tilt mechanism shall permit the kettle to tilt forward a full 90° for complete emptying. The tilt mechanism shall be self locking for positive stop action.

### MIXER FEATURES:

The mixer is a variable speed unit powered by a 5 hp electric motor driving a hydraulic pump. Two agitators shall be included, a primary stainless steel scraper/agitator, and a secondary high speed mixer. Both agitators shall be removable for cleaning and no tools will be required for removal.

The console front to have the main power switch, mixer lift switch and variable speed control.

The bridge is constructed of 10 gauge stainless steel and contains two heavy duty hydraulic motors to drive the agitators. The bridge shall be power tilt, and swing 140° out of the way for kettle tilting or cleaning.



Models:

KDMTL-40

KDMTL-60

KDMTL-80

KDMTL-100

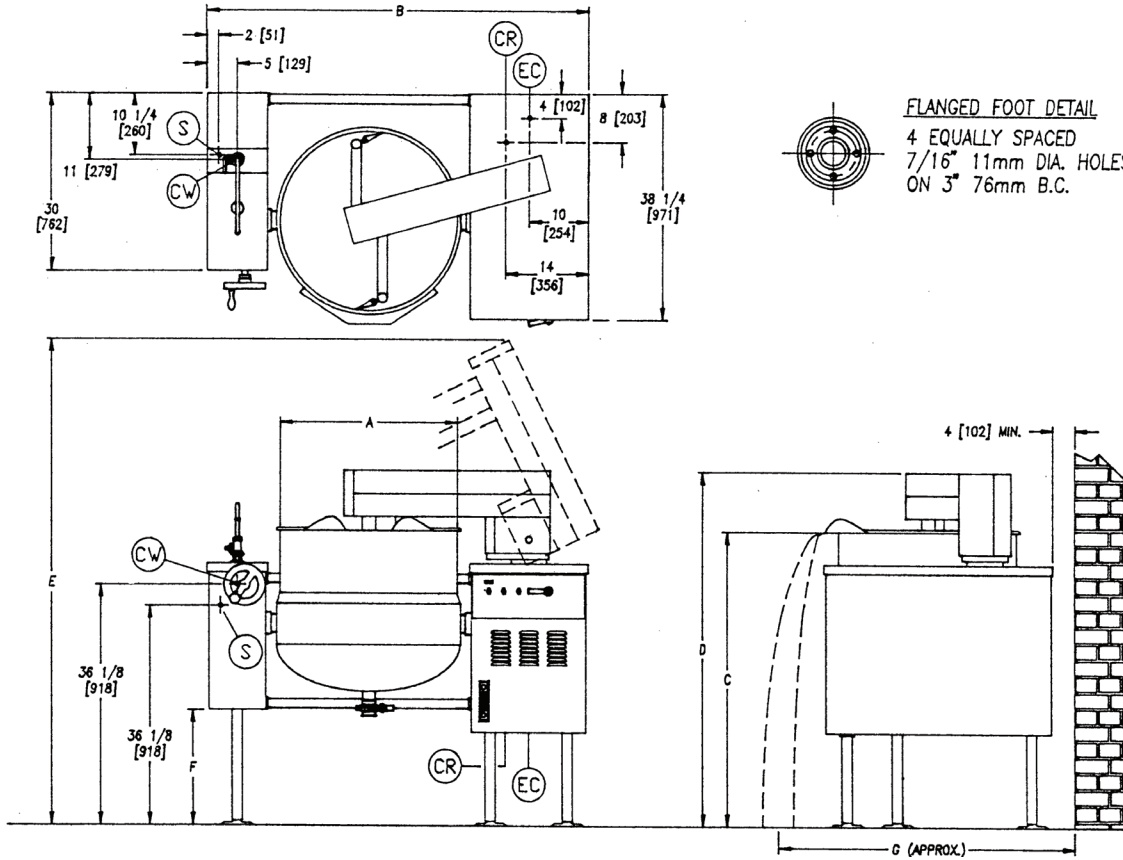

**SERVICE CONNECTIONS**

EC - ELECTRICAL CONNECTION: As specified by data plate

S - STEAM SUPPLY: 3/4" IPS (19 mm)

CW - COLD WATER: 3/8" (10 mm) nominal tubing to kettle fill faucet (OPTIONAL)

CR - CONDENSATE RETURN: 1/2" IPS (13 mm)

**DIMENSIONS**

MODEL	CAPACITY	UNITS	A	B	C	D	E	F	G
KDMTL-40	40 Gallons (152 liters)	inches (mm)	26" (660)	62" (1575)	45.5" (1156)	55" (1397)	75.63" (1921)	15.13" (384)	56" (1422)
KDMTL-60	60 Gallons (227 liters)	inches (mm)	29.5" (749)	65" (1651)	49" (1245)	58.5" (1486)	80" (2032)	19.5" (495)	58" (1473)
KDMTL-80	80 Gallons (303 liters)	inches (mm)	33" (838)	67.75" (1721)	49" (1245)	58.5" (1486)	80" (2032)	19.5" (495)	60" (1524)
KDMTL-100	100 Gallons (380 liters)	inches (mm)	35.5" (902)	70" (1778)	49" (1245)	58.5" (1486)	85" (2159)	19.5" (495)	63" (1600)

**ELECTRICAL CHARACTERISTICS**

MODEL	AMPS PER LINE		
	208V	240V	480V
KDMTL-40	14.0	14.0	7.0
KDMTL-60			
KDMTL-80			
KDMTL-100			

**INTENDED FOR COMMERCIAL USE ONLY.  
NOT FOR HOUSEHOLD USE.**



1100 Old Honeycutt Road, Fuquay-Varina, NC 27526  
(919) 762-1000 www.southbendnc.com