

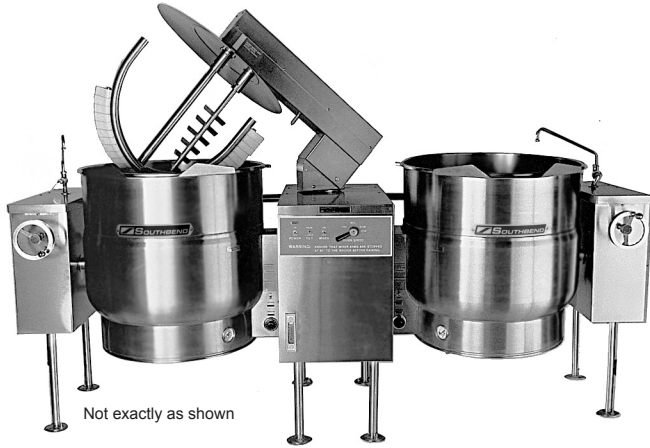

# ELECTRIC LEG-MOUNTED TWIN TILTING MIXER KETTLES

Job  
#



Not exactly as shown

MODEL	CAPACITY	
KEMTL-40-2	2 x 40 Gallon	2 x 152 Liter
KEMTL-60-2	2 x 60 Gallon	2 x 227 Liter
KEMTL-80-2	2 x 80 Gallon	2 x 303 Liter
KEMTL-100-2	2 x 100 Gallon	2 x 380 Liter

### OPERATION SHALL BE BY:

Electrically, self-generating closed steam system equipped for operation on:

- 208 Volts, 3 Phase, 60 Hz
- 240 Volts, 3 Phase, 60 Hz

### OPTIONAL ITEMS AT EXTRA COST:

- Swing faucet on left or right console
- 3" manual butterfly valve
- 2" manual butterfly valve
- 316 stainless steel liner for high acid content products
- 33 KW elements
- 380 or 415 VAC, 50 Hz, 3 Phase
- 440, 460 or 480 VAC, 60 Hz, 3 Phase
- 575 or 600 VAC, 60 Hz, 3 Phase (not UL)

### SPECIFICATIONS:

Shall be a Southbend Model \_\_\_\_\_, self-generating, twin electric kettle. Construction shall be welded stainless steel type 304 satin finish. A double wall kettle interior shall form a steam jacket around the lower 2/3 of the kettle. The bottom of the kettle shall be of hemispheric design for maximum heat transfer. The tubular legs shall be constructed of stainless steel pipe fitted with four hole, adjustable, flanged feet for securing to the floor. A sealed stainless steel tilt mechanism shall permit the kettle to tilt forward a full 90° for complete emptying. The tilt mechanism shall be self locking for positive stop action. Kettle controls shall include a power switch, thermostat, power "on" light (pilot light) vacuum/pressure gauge, pressure relief valve and low water shut off. Thermostat range to be 140°F to 285°F (60°C to 140°C), a maximum pressure of 50 psi (345 kPa). Electric elements to be removable.

### MIXER FEATURES:

The mixer is a variable speed unit powered by a 5 hp electric motor driving a hydraulic pump. Two agitators shall be included, a primary stainless steel scraper/agitator, and a secondary high speed mixer. Both agitators shall be removable for cleaning and no tools will be required for removal.

The console front to have the main power switch, mixer lift switch and variable speed control.

The bridge is constructed of 10 gauge stainless steel and contains two heavy duty hydraulic motors to drive the agitators. The bridge shall be power tilt, and swing 140° out of the way for kettle tilting or cleaning.



Models:  KEMTL-40-2

KEMTL-60-2

KEMTL-80-2

KEMTL-100-2

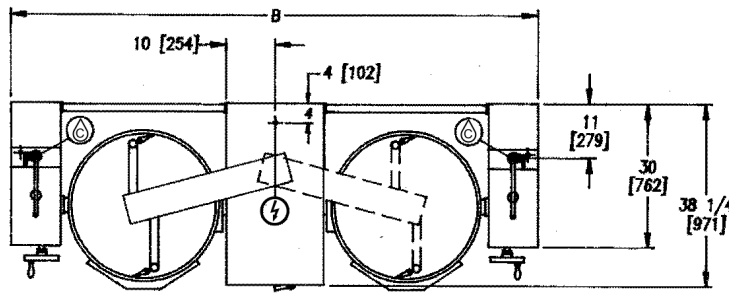

FLANGED FOOT DETAIL  
4 EQUALLY SPACED  
Ø 7/16" (11mm) HOLES  
ON 3" (76mm) B.C.

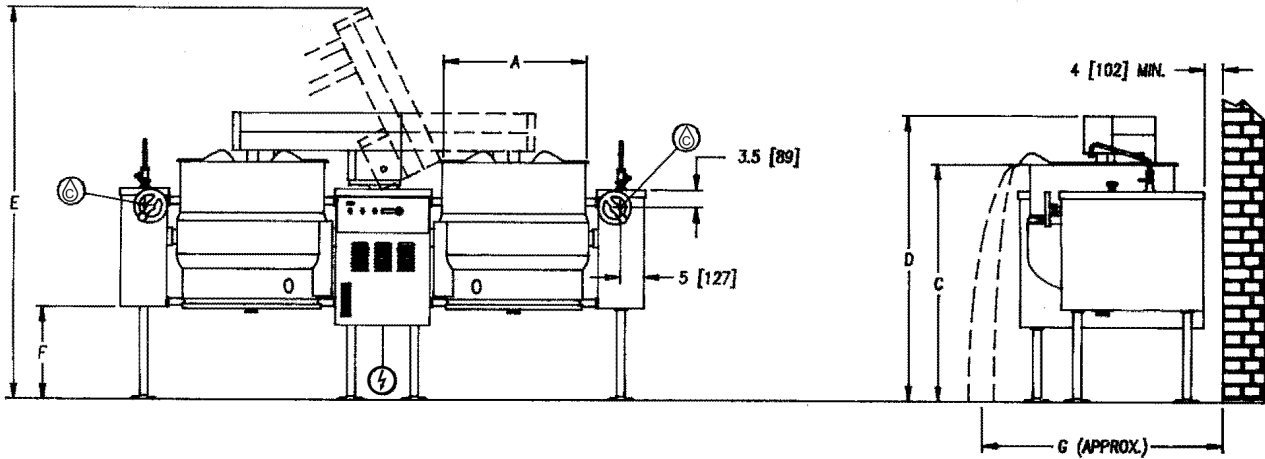

**SERVICE CONNECTIONS**

- COLD WATER: 3/8" (10mm) nominal tubing to kettle fill faucet (Optional)
- ELECTRICAL CONNECTION: As specified by data plate

**DIMENSIONS**

MODEL	CAPACITY	UNITS	A	B	C	D	E	F	G
KEMTL-40-2	40 Gal Each (151 liters)	inches (mm)	26" (660)	102" (2591)	45.5" (1156)	55" (1397)	75.63" (1921)	15.13" (384)	56" (1422)
KEMTL-60-2	60 Gal Each (227 liters)	inches (mm)	29.5" (749)	108" (2743)	49" (1245)	58.5" (1486)	80" (2032)	19.5" (495)	58" (1473)
KEMTL-80-2	80 Gal Each (303 liters)	inches (mm)	33" (838)	116" (2946)	49" (1245)	58.5" (1486)	80" (2032)	19.5" (495)	60" (1524)
KEMTL-100-2	100 Gal Each (380 liters)	inches (mm)	35.5" (902)	121" (3073)	49" (1245)	58.5" (1486)	85" (2159)	19.5" (495)	63" (1600)

**ELECTRICAL CHARACTERISTICS**

MODEL	208V		240V		480V	
	κW	AMP	κW	AMP	κW	AMP
KEMTL-40-2	24	147.2	24	129.6	24	64.8
KEMTL-60-2						
KEMTL-80-2	33	197.4	33	172.8	33	86.4
KEMTL-100-2						

**INTENDED FOR COMMERCIAL USE ONLY.  
NOT FOR HOUSEHOLD USE.**



1100 Old Honeycutt Road, Fuquay-Varina, NC 27526  
(919) 762-1000 www.southbendnc.com