



# SECTIONAL DEEP FRYER

16" 45lb and 20" 65lb Sectional Fryer

## Platinum Series

### Standard Features

- Available in 45lb and 65lb capacity
- 9" front rail to match Sectional Range
- Stainless steel tank and cabinet
- Two twin plated, mesh fry basket with plastic coated, heat resistant handles
- Quick recovery is provided to eliminate waiting between loads
- Wide spacing tube frypot -allows more heat to be transferred to oil and easy cleaning
- 1-1/4" full port drain valve helps eliminate clogging
- Large cold zone captures food particles, reduces flavor transfer and extends oil life
- Single unit combination gas shut-off, pressure regulator and pilot ignition system
- 6" adjustable legs front, 6" fixed casters rear
- 1-1/4" front manifold with 1" rear gas connection standard
- 100% safety shut off
- Warranty: Two years parts, one year labor
- Adjustable legs in front and rigid caster in rear

#### New Pitco Solstice burner/baffle design:

- Increases cooking production.
- Lowers flue temperature.
- Improves working environment.
- Generates more production per BTU.

\* 24" MINIMUM FLUE RISER REQUIRED \*

45 lb Sectional Fryer  
P16-PF45

65 lb Sectional Fryer  
P20-PF65



(shown with 36" high flue riser)

Job  
#

### STANDARD CONSTRUCTION SPECIFICATIONS

**Exterior Finish:** Stainless steel front.

**Frypot:** 16-gauge, type 430 #3 Welded tank with an extra smooth peened finish ensures easy cleaning. Long-lasting, high-temperature alloy stainless steel heat baffles are mounted in the heat exchanger tubes to provide maximum heating and combustion efficiency. Front access, quick opening 1-1/4" drain valve.

**Gas Control System:** Includes manual shut-off, 100% safety shut-off pilot gas filter, pilot adjustment and 200° to 400° adjustable thermostat. High limit control automatically shuts down main burner and pilot if oil temperature exceeds 475°F.

**Optional Oil Filtration:** Simple two-step operation:

1. Blue handle valve is opened to drain oil into filter pan.
2. Red handle valve is opened to return oil from filter to fryer.

- Self-aligning filter piping makes it easy to assemble and disassemble.
- Larger 3" (7.6 cm) drain line allows for faster draining without clogging.
- Light-weight, removable filter pickup assembly, with built-in handle, for fast media cleaning under busy conditions.
- High flow pump and large return lines produce faster oil refill times.
- Large filter media collects more debris, which extends time between changes.



Models:  P16-PF45  P20-PF65

SHIPPING CRATE DIMENSIONS & WEIGHT (Door-entry clearance when uncrated is 16.5" for Model P16-PF45 and 20.5" for Model P20-PF65)					
Model	Width	Height	Depth	Volume	Weight
P16-PF45	20.0 (508)	45.0 (1143)	42.5 (1080)	22.1 cu ft (0.63 cu m)	210 lbs (95 kg)
P20-PF65	23.0 (584)	41.0 (1041)	43.0 (1092)	23.5 cu ft (0.66 cu m)	265 lbs (120 kg)

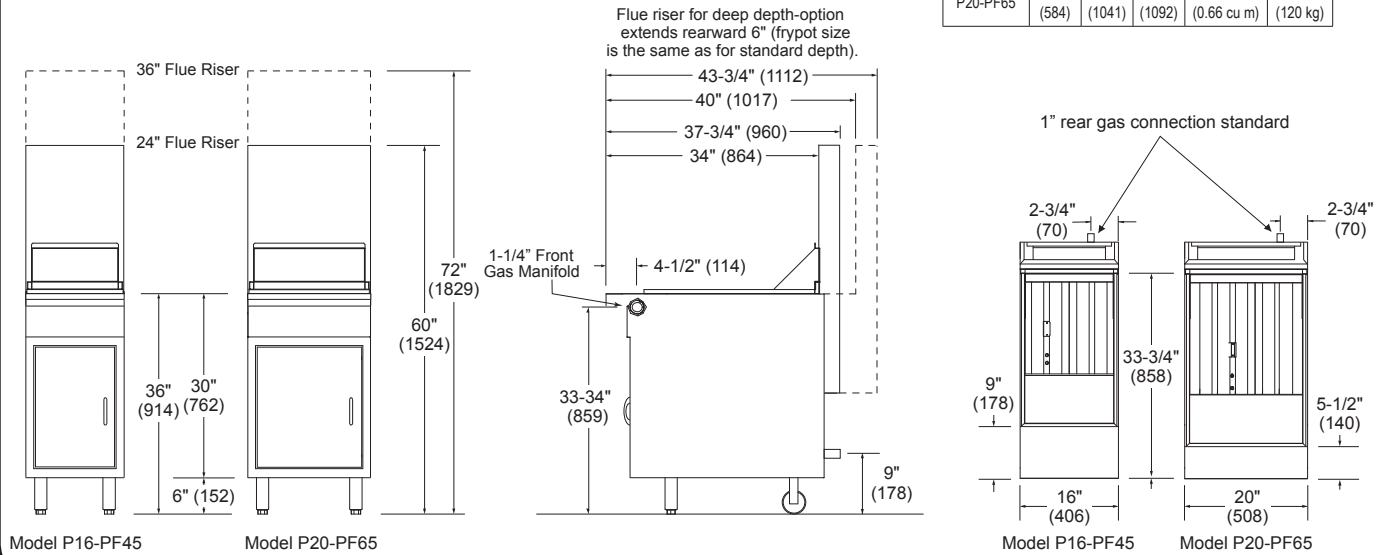

### UTILITY INFORMATION

GAS	
Model	Natural/Propane BTU/Hour
P16-PF45	110,000
P20-PF65	150,000

GAS: Each unit has a 1-1/4" front gas manifold that couples to the adjacent sectional unit(s), and a 1" NPT male rear gas connection (See plan view note above). Minimum supply pressure is 7" W.C. for natural gas and 11" W.C. for propane. All sectional units require a regulated gas supply; pressure regulator to be ordered separately. If using a flexible hose gas connection, the I.D. of the hose must not be smaller than the connector on the unit and must comply with ANSI Z21.69, providing an adequate means of restraint to prevent undue strain on the gas connection

### MISCELLANEOUS

- If casters are used with flex hose, a restraining device should be used to eliminate undue strain on the flex hose.
- Minimum clearance from noncombustible construction is zero. Minimum clearance from combustible construction is 10" on sides and 6" on rear.
- Install under vented hood.
- Check local codes for fire and sanitary regulations.

#### NOTICE:

Southbend has a policy of continuous product research and improvement. We reserve the right to change specifications and product design without notice. Such revisions do not entitle the buyer to corresponding changes, improvements, additions or replacements for previously purchased equipment.

### OPTIONS AND ACCESSORIES

- Fryer filter system (7.0 A, 120 V, 1 phase)
- Extra twin size basket for 14" pot
- Flue Risers: 24", 36" (minimum 24" flue riser required)
- Stainless steel frypot cover
- Stainless steel sides
- Heat lamp over drain cabinet
- Extra single basket (full size) for 14" pot
- Stainless steel divider
- Cable restraint kit

**INTENDED FOR COMMERCIAL USE ONLY.  
NOT FOR HOUSEHOLD USE.**



1100 Old Honeycutt Road, Fuquay-Varina, NC 27526  
(919) 762-1000 www.southbendnc.com